



BELT DRIVE

- Rugged heavy gauge galvanized housing, frame and blade
- Galvanized welded bird screen on both front and back
- Rolled Inlet Venturi for efficient air flow
- Totally Enclosed motors
- Consult factory for 115V models

FOUR BLADE MODELS

Diameter	Model	Volts	HP	Amps	RPM	0.00" SP		0.05" SP		0.10" SP		Approximate Weight
						CFM	CFM/Watt	CFM	CFM/Watt	CFM	CFM/Watt	
36"	PFG 3613	230/1	1/2	3.8	550	10,406	16.3	9,478	14.3	8,432	12.4	132
42"	PFG 4213	230/1	1/2	3.8	499	12,678	19.9	11,736	17.4	10,615	15.2	160
48"	PFG 4815	230/1	1	5.5	475	19,504	18.5	18,056	16.8	16,330	15.0	194
54"	PFG 5415	230/1	1	5.5	450	22,917	22.9	21,048	20.6	18,784	17.7	237

SIX BLADE MODELS

Diameter	Model	Volts	HP	Amps	RPM	0.00" SP		0.05" SP		0.10" SP		Approximate Weight
						CFM	CFM/Watt	CFM	CFM/Watt	CFM	CFM/Watt	
36"	PFG 36136	230/1	1/2	3.8	560	11,010	16.5	10,450	14.6	9,820	13.3	137
42"	PFG 42136	230/1	1/2	3.8	494	13,610	20.4	12,050	17.7	11,215	15.1	165
48"	PFG 48156	230/1	1	5.5	482	19,723	18.5	18,436	16.7	16,992	14.9	201
54"	PFG 54156	230/1	1	5.5	419	23,214	22.0	21,566	19.8	19,708	17.6	242

*Performance data includes the effect of a shutter.

Diameter	A	B
36"	40 3/4"	20"
42"	46 3/4"	20"
48"	52 3/4"	20"
54"	60 3/4"	20"

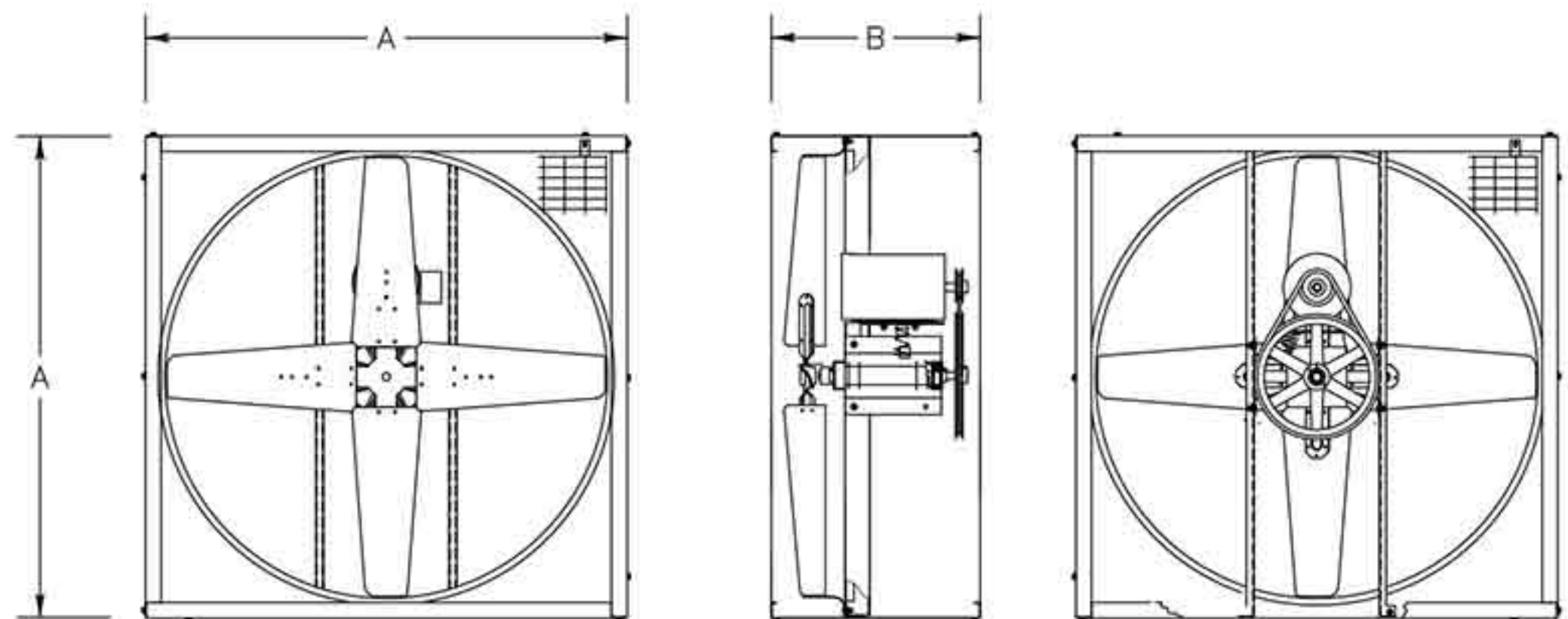

AGRICULTURAL FANS: BELT DRIVE PFG

Triangle Engineering Inc. 1-501-982-7558 1101 North Redmond Rd, Jacksonville, AR 72076 www.trianglefans.com