



General Characteristics of MCD Series Medium Stand Explosion Proof Industrial Direct Drive Blowers

These MCD Series motors come in the explosion proof option. Can be used in industrial or commercial areas. For indoor use. Used for cooling and high-volume air movement. The blades are made of cast aluminum; the body and stand are made from 14-gauge steel. This product comes with the option of an acid resistant coating. Call or email for quote. For safety, the CPB Series are designed with spiral wire front and rear guards. Finished off with a baked enamel coating. The high and medium stand units have a 360° swivel. Explosion proof motors are Class 1, Div. 1, Group D and Class 2 Div. 1, Groups F & G. Single phase motors are field convertible 115V/230V. Three phase motors are field convertible 230V/460V. Motors are set to lower voltage at the factory unless a request is made at the time of order to set to the higher voltage. Note: products listed are custom built and subject to 100% cancellation/restocking charges. The MCD Series meets OSHA requirements.



Product Applications of MCD Series Medium Stand Explosion Proof Industrial Direct Drive Blowers

For industrial and commercial use. Used for cooling factories, shops, bakeries, loading docks, laundries, gymnasiums, warehouses, aircraft hangars, and virtually any place a high volume of air movement is required. For indoor use.

Warranty of MCD Series Medium Stand Explosion Proof Industrial Direct Drive Blowers

Manufacturer's Warranty: 1 year.

Specific Characteristics of MCD Series Medium Stand Explosion Proof Industrial Direct Drive Blowers

Item #	Manufacturing #	Size Ø(In.)	CFM	Volts	Amperes A	Phases Ph	HP	RPM	DB'S	Stand Type	Weight and Dimensions with Packaging	
											Lbs.	L,W,H In.
USMSE-001	MCD18-1/4-M EXP	18	3050	115/230	2.25/1.13	1	1/4	1725	74	Medium Stand	105	34,25,40
USMSE-002	MCD18-1/4-M-3 EXP	18	3050	230/460	0.73/0.36	3	1/4	1725	74	Medium Stand	105	34,25,40
USMSE-003	MCD18-1/3-M EXP	18	3450	115/230	2.97/1.49	1	1/3	1725	76	Medium Stand	107	34,25,40
USMSE-004	MCD18-1/3-M-3 EXP	18	3450	230/460	0.95/0.74	3	1/3	1725	76	Medium Stand	107	34,25,40



MCD Series
Medium Stand Explosion Proof
Industrial Heavy Duty
Direct Drive Blower
 Data Sheet

Item #	Manufacturing #	Size Ø(In.)	CFM	Volts	Amperes A	Phases Ph	HP	RPM	DB'S	Stand Type	Weight and Dimensions with Packaging	
											Lbs.	L,W,H In.
USMSE-005	MCD18-1-M EXP	18	4600	115/230	9.01/4.5	1	1	1725	77	Medium Stand	235	34,25,40
USMSE-006	MCD18-1-M-3 EXP	18	4600	230/460	2.89/1.45	3	1	1725	77	Medium Stand	235	34,25,40
USMSE-007	MCD24-1/4-M EXP	24	5200	115/230	2.25/1.13	1	1/4	1725	80	Medium Stand	235	34,31,43
USMSE-008	MCD24-1/4-M-3 EXP	24	5200	230/460	0.73/0.36	3	1/4	1725	80	Medium Stand	235	34,31,43
USMSE-009	MCD24-1/3-M EXP	24	5300	115/230	2.97/1.49	1	1/3	1140	74	Medium Stand	255	34,31,43
USMSE-010	MCD24-1/3-M-3 EXP	24	5300	230/460	0.95/0.74	3	1/3	1140	74	Medium Stand	255	34,31,43
USMSE-011	MCD24-1/2-M EXP	24	6000	115/230	4.5/2.25	1	1/2	1725	80	Medium Stand	245	34,31,43
USMSE-012	MCD24-1/2-M-3 EXP	24	6000	230/460	1.45/0.73	3	1/2	1725	80	Medium Stand	245	34,31,43
USMSE-013	MCD24-3/4-M EXP	24	6900	115/230	6.76/3.38	1	3/4	1140	74	Medium Stand	265	34,31,43
USMSE-014	MCD24-3/4-M-3 EXP	24	6900	230/460	2.16/1.09	3	3/4	1140	74	Medium Stand	265	34,31,43
USMSE-015	MCD24-1-M EXP	24	7400	115/230	9.01/4.5	1	1	1725	82	Medium Stand	255	34,31,43
USMSE-016	MCD24-1-M-3 EXP	24	7400	230/460	2.89/1.45	3	1	1725	82	Medium Stand	255	34,31,43
USMSE-017	MCD24-1 1/2-M EXP	24	8200	115/230	13.5/6.76	1	1 1/2	1725	84	Medium Stand	260	34,31,43
USMSE-018	MCD24-1 1/2-M-3 EXP	24	8200	230/460	4.34/2.16	3	1 1/2	1725	84	Medium Stand	260	34,31,43
USMSE-019	MCD24-3-M-3 EXP	24	10500	230/460	8.68/4.34	3	3	1725	87	Medium Stand	275	34,31,43
USMSE-020	MCD30-1/3-M EXP	30	6900	115/230	2.97/1.49	1	1/3	1140	80	Medium Stand	265	34,37,46
USMSE-021	MCD30-1/3-M-3 EXP	30	6900	230/460	0.95/0.74	3	1/3	1140	80	Medium Stand	265	34,37,46
USMSE-022	MCD30-1/2-M EXP	30	8900	115/230	4.5/2.25	1	1/2	1725	86	Medium Stand	255	34,37,46
USMSE-023	MCD30-1/2-M-3 EXP	30	8900	230/460	1.45/0.73	3	1/2	1725	86	Medium Stand	255	34,37,46
USMSE-024	MCD30-3/4-M EXP	30	10400	115/230	6.76/3.38	1	3/4	1140	80	Medium Stand	320	34,37,46
USMSE-025	MCD30-3/4-M-3 EXP	30	10400	230/460	2.16/1.09	3	3/4	1140	80	Medium Stand	320	34,37,46
USMSE-026	MCD30-1-M EXP	30	11200	115/230	9.01/4.5	1	1	1140	81	Medium Stand	315	34,37,46
USMSE-027	MCD30-1-M-3 EXP	30	11200	230/460	2.89/1.45	3	1	1140	81	Medium Stand	315	34,37,46
USMSE-028	MCD30-1 1/2-M EXP	30	12000	115/230	13.5/6.76	1	1 1/2	1725	92	Medium Stand	315	34,37,46
USMSE-029	MCD30-1 1/2-M-3 EXP	30	12000	230/460	4.34/2.16	3	1 1/2	1725	92	Medium Stand	315	34,37,46
USMSE-030	MCD30-2-M-3 EXP	30	14000	230/460	5.78/2.89	3	2	1140	84	Medium Stand	335	34,37,46
USMSE-031	MCD30-3-M-3 EXP	30	16000	230/460	8.68/4.34	3	3	1725	94	Medium Stand	330	34,37,46
USMSE-032	MCD36-1-M EXP	36	13000	115/230	9.01/4.5	1	1	1140	82	Medium Stand	380	34,43,47
USMSE-033	MCD36-1-M-3 EXP	36	13000	230/460	2.89/1.45	3	1	1140	82	Medium Stand	380	34,43,47
USMSE-034	MCD36-1 1/2-M EXP	36	14850	115/230	13.5/6.76	1	1 1/2	1725	88	Medium Stand	380	34,43,47
USMSE-035	MCD36-1 1/2-M-3 EXP	36	14850	230/460	4.34/2.16	3	1 1/2	1725	88	Medium Stand	380	34,43,47
USMSE-036	MCD36-2-M-3 EXP	36	17500	230/460	5.78/2.89	3	2	1140	82	Medium Stand	385	34,43,47
USMSE-037	MCD36-3-M-3 EXP	36	18500	230/460	8.68/4.34	3	3	1725	90	Medium Stand	395	34,43,47
USMSE-038	MCD36-5-M-3 EXP	36	23000	230/460	14.5/7.23	3	5	1725	94	Medium Stand	395	34,43,47
USMSE-039	MCD42-2-M-3 EXP	42	19500	230/460	5.78/2.89	3	2	1140	85	Medium Stand	570	34,49,50
USMSE-040	MCD42-5-M-3 EXP	42	27000	230/460	14.5/7.23	3	5	1725	98	Medium Stand	575	34,49,50
USMSE-041	MCD48-5-M-3 EXP	48	32000	230/460	14.5/7.23	3	5	1140	92	Medium Stand	715	34,55,63
USMSE-042	MCD48-7 1/2-M-3 EXP	48	37000	230/460	21.6/10.8	3	7 1/2	1140	105	Medium Stand	840	34,55,63
USMSE-043	MCD48-10-M-3 EXP	48	41000	230/460	28.9/14.5	3	10	1140	105	Medium Stand	895	34,55,63



Dimensions (In.) of MCD Series Medium Stand Explosion Proof Industrial Direct Drive Blowers

Series	Length A	Width B	Height C
USMSE-001 to 006	32"	23 1/2"	38"
USMSE-007 to 019	32"	29 1/2"	41"
USMSE-020 to 031	32"	35 1/2"	44"
USMSE-032 to 038	32"	41 1/2"	47"
USMSE-039 & 040	32"	47 1/2"	50"
USMSE-041 to 043	32"	53 1/2"	61 1/2"

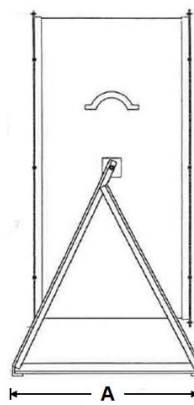
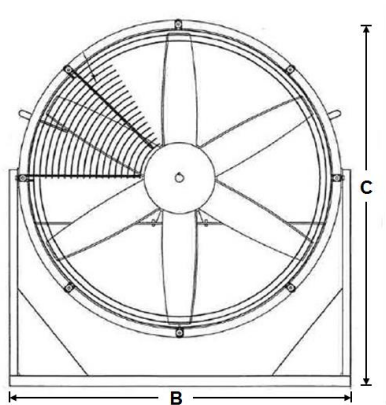



MCD Series Medium Stand Explosion Proof Industrial Direct Drive Blowers

Ratings Definitions

Class I: Equipment does not have surface operating temperature in excess of the ignition temperature of the specific gas or vapor.

Application Examples:

- Offshore and land based drilling rigs, petroleum exploration and testing facilities.
- Petroleum refineries, gasoline storage and dispensing areas.
- Industrial firms that use flammable liquids in dip tanks for parts cleaning or other operations.
- Petrochemical companies that manufacture chemicals from gas or oil.
- Dry cleaning facilities where vapors from cleaning fluids may be present.
- Aircraft hangers and fuel servicing areas.
- Utility gas plants and operations involving storage and handling of liquefied petroleum or natural gas.

Group D: Atmospheres such as but not limited to acetone, alcohol, gasoline, lacquer solvent vapors, natural gas, propane or other gases or vapors of equivalent hazard.

Class II: Equipment does not have surface temperature greater than the ignition temperature of the specified dust.

Application Examples:

- Coal preparation plants and other carbon handling or processing areas.
- Grain elevators, flour and feed mills.
- Plants which manufacture, use or store Magnesium or Aluminum powders.
- Plants that have chemical or metallurgical processes.
- Producers of starch products or candy.
- Spice grinding plants, sugar plants and cocoa plants.

Group F: Atmosphere containing carbon black, charcoal, coal or coke dust.

Group G: Atmospheres containing combustible dust having resistivity of 10^5 OHM-centimeter or greater.

Division I: A location in which ignitable concentrations of flammable material exist under normal operating conditions.

Division II: Locations in which flammable materials will normally be confined within closed containers and escape only in the case of accidental rupture, breakdown or during maintenance operations. Any equipment approved for Division I is automatically also approved for Division II.



Short Description of MCD Series Medium Stand Explosion Proof Industrial Direct Drive Blowers		
Item #	Manufacturing #	Short Description 70 Characters Maximum
		0123456789012345678901234567890123456789012345678901234567890123456789
USMSE-001	MCD 18-1/4-M EXP	18"Ø, 3050CFM, 115/230V, 2.25/1.13A, 1Ph, 1/4HP Explosion Proof Motor, 1725RPM, 74DB'S, Medium Stand.
USMSE-002	MCD18-1/4-M-3 EXP	18"Ø, 3050CFM, 230/460V, 0.73/0.36A, 3Ph, 1/4HP Explosion Proof Motor, 1725RPM, 74DB'S, Medium Stand.
USMSE-003	MCD18-1/3-M EXP	18"Ø, 3450CFM, 115/230V, 2.97/1.49A, 1Ph, 1/3HP Explosion Proof Motor, 1725RPM, 76DB'S, Medium Stand.
USMSE-004	MCD18-1/3-M-3 EXP	18"Ø, 3450CFM, 230/460V, 0.95/0.74A, 3Ph, 1/3HP Explosion Proof Motor, 1725RPM, 76DB'S, Medium Stand.
USMSE-005	MCD18-1-M EXP	18"Ø, 4600CFM, 115/230V, 9.01/4.5A, 1Ph, 1HP Explosion Proof Motor, 1725RPM, 77DB'S, Medium Stand.
USMSE-006	MCD18-1-M-3 EXP	18"Ø, 4600CFM, 230/460V, 2.89/1.45A, 3Ph, 1HP Explosion Proof Motor, 1725RPM, 77DB'S, Medium Stand.
USMSE-007	MCD24-1/4-M EXP	24"Ø, 5200CFM, 115/230V, 2.25/1.13A, 1Ph, 1/4HP Explosion Proof Motor, 1725RPM, 80DB'S, Medium Stand.
USMSE-008	MCD24-1/4-M-3 EXP	24"Ø, 5200CFM, 230/460V, 0.73/0.36A, 3Ph, 1/4HP Explosion Proof Motor, 1725RPM, 80DB'S, Medium Stand.
USMSE-009	MCD24-1/3-M EXP	24"Ø, 5300CFM, 115/230V, 2.97/1.49A, 1Ph, 1/3HP Explosion Proof Motor, 1140RPM, 74DB'S, Medium Stand.
USMSE-010	MCD24-1/3-M-3 EXP	24"Ø, 5300CFM, 230/460V, 0.95/0.79A, 3Ph, 1/3HP Explosion Proof Motor, 1140RPM, 74DB'S, Medium Stand.
USMSE-011	MCD24-1/2-M EXP	24"Ø, 6000CFM, 115/230V, 4.5/2.25A, 1Ph, 1/2HP Explosion Proof Motor, 1725RPM, 80DB'S, Medium Stand.
USMSE-012	MCD24-1/2-M-3 EXP	24"Ø, 6000CFM, 230/460V, 1.45/0.73A, 3Ph, 1/2HP Explosion Proof Motor, 1725RPM, 80DB'S, Medium Stand.
USMSE-013	MCD24-3/4-M EXP	24"Ø, 6900CFM, 115/230V, 6.76/3.38A, 1Ph, 3/4HP Explosion Proof Motor, 1140RPM, 74DB'S, Medium Stand.
USMSE-014	MCD24-3/4-M-3 EXP	24"Ø, 6900CFM, 230/460V, 2.16/1.09A, 3Ph, 3/4HP Explosion Proof Motor, 1140RPM, 74DB'S, Medium Stand.
USMSE-015	MCD24-1-M EXP	24"Ø, 7400CFM, 115/230V, 9.01/4.5A, 1Ph, 1HP Explosion Proof Motor, 1725RPM, 82DB'S, Medium Stand.
USMSE-016	MCD24-1-M-3 EXP	24"Ø, 7400CFM, 230/460V, 2.89/1.45A, 3Ph, 1HP Explosion Proof Motor, 1725RPM, 82DB'S, Medium Stand.
USMSE-017	MCD24-1 1/2-M EXP	24"Ø, 8200CFM, 115/230V, 13.5/6.76A, 1Ph, 1 1/2HP Explosion Proof Motor, 1725RPM, 84DB'S, Medium Stand.
USMSE-018	MCD24-1 1/2-M-3 EXP	24"Ø, 8200CFM, 230/460V, 4.34/2.16A, 3Ph, 1 1/2HP Explosion Proof Motor, 1725RPM, 84DB'S, Medium Stand.
USMSE-019	MCD24-3-M-3 EXP	24"Ø, 10500CFM, 230/460V, 8.68/4.34A, 3Ph, 3HP Explosion Proof Motor, 1725RPM, 87DB'S, Medium Stand.
USMSE-020	MCD30-1/3-M EXP	30"Ø, 6900CFM, 115/230V, 2.97/1.49A, 1Ph, 1/3HP Explosion Proof Motor, 1140RPM, 80DB'S, Medium Stand.
USMSE-021	MCD30-1/3-M-3 EXP	30"Ø, 6900CFM, 230/460V, 0.95/0.74A, 3Ph, 1/3HP Explosion Proof Motor, 1140RPM, 80DB'S, Medium Stand.
USMSE-022	MCD30-1/2-M EXP	30"Ø, 8900CFM, 115/230V, 4.5/2.25A, 1Ph, 1/2HP Explosion Proof Motor, 1725RPM, 86DB'S, Medium Stand.
USMSE-023	MCD30-1/2-M-3 EXP	30"Ø, 8900CFM, 230/460V, 1.45/0.73A, 3Ph, 1/2HP Explosion Proof Motor, 1725RPM, 86DB'S, Medium Stand.
USMSE-024	MCD30-3/4-M EXP	30"Ø, 10400CFM, 115/230V, 6.76/3.38A, 1Ph, 3/4HP Explosion Proof Motor, 1140RPM, 80DB'S, Medium Stand.
USMSE-025	MCD30-3/4-M-3 EXP	30"Ø, 10400CFM, 230/460V, 2.16/1.09A, 3Ph, 3/4HP Explosion Proof Motor, 1140RPM, 80DB'S, Medium Stand.
USMSE-026	MCD30-1-M EXP	30"Ø, 11200CFM, 115/230V, 9.01/4.5A, 1Ph, 1HP Explosion Proof Motor, 1140RPM, 81DB'S, Medium Stand.



Item #	Manufacturing #	Short Description 70 Characters Maximum		
		0123456789012345678901234567890123456789012345678901234567890123456789		
USMSE-027	MCD30-1-M-3 EXP	30"Ø, 11200CFM, 230/460V, 2.89/1.45A, 3Ph, 1HP Explosion Proof Motor, 1140RPM, 81DB'S, Medium Stand.		
USMSE-028	MCD30-1 1/2-M EXP	30"Ø, 12000CFM, 115/230V, 13.5/6.76A, 1Ph, 1 1/2HP Explosion Proof Motor, 1725RPM, 92DB'S, Medium Stand.		
USMSE-029	MCD30-1 1/2-M-3 EXP	30"Ø, 12000CFM, 230/460V, 4.34/2.16A, 3Ph, 1 1/2HP Explosion Proof Motor, 1725RPM, 92DB'S, Medium Stand.		
USMSE-030	MCD30-2-M-3 EXP	30"Ø, 14000CFM, 230/460V, 5.78/2.89A, 3Ph, 2HP Explosion Proof Motor, 1140RPM, 84DB'S, Medium Stand.		
USMSE-031	MCD30-3-M-3 EXP	30"Ø, 16000CFM, 230/460V, 8.68/4.34A, 3Ph, 3HP Explosion Proof Motor, 1725RPM, 94DB'S, Medium Stand.		
USMSE-032	MCD36-1-M EXP	36"Ø, 13000CFM, 115/230V, 9.01/4.5A, 1Ph, 1HP Explosion Proof Motor, 1140RPM, 82DB'S, Medium Stand.		
USMSE-033	MCD36-1-M-3 EXP	36"Ø, 13000CFM, 230/460V, 2.89/1.45A, 3Ph, 1HP Explosion Proof Motor, 1140RPM, 82DB'S, Medium Stand.		
USMSE-034	MCD36-1 1/2-M EXP	36"Ø, 14850CFM, 115/230V, 13.5/6.76A, 1Ph, 1 1/2HP Explosion Proof Motor, 1725RPM, 88DB'S, Medium Stand.		
USMSE-035	MCD36-1 1/2-M-3 EXP	36"Ø, 14850CFM, 230/460V, 4.34/2.16A, 3Ph, 1 1/2HP Explosion Proof Motor, 1725RPM, 88DB'S, Medium Stand.		
USMSE-036	MCD36-2-M-3 EXP	36"Ø, 17500CFM, 230/460V, 5.78/2.89A, 3Ph, 2HP Explosion Proof Motor, 1140RPM, 82DB'S, Medium Stand.		
USMSE-037	MCD36-3-M-3 EXP	36"Ø, 18500CFM, 230/460V, 8.68/4.34A, 3Ph, 3HP Explosion Proof Motor, 1725RPM, 90DB'S, Medium Stand.		
USMSE-038	MCD36-5-M-3 EXP	36"Ø, 23000CFM, 230/460V, 14.5/7.23A, 3Ph, 5HP Explosion Proof Motor, 1725RPM, 94DB'S, Medium Stand.		
USMSE-039	MCD42-2-M-3 EXP	42"Ø, 19500CFM, 230/460V, 5.78/2.89A, 3Ph, 2HP Explosion Proof Motor, 1140RPM, 85DB'S, Medium Stand.		
USMSE-040	MCD42-5-M-3 EXP	42"Ø, 27000CFM, 230/460V, 14.5/7.23A, 3Ph, 5HP Explosion Proof Motor, 1725RPM, 98DB'S, Medium Stand.		
USMSE-041	MCD48-5-M-3 EXP	48"Ø, 32000CFM, 230/460V, 14.5/7.23A, 3Ph, 5HP Explosion Proof Motor, 1140RPM, 92DB'S, Medium Stand.		
USMSE-042	MCD48-7 1/2-M-3 EXP	48"Ø, 37000CFM, 230/460V, 21.6/7.23A, 3Ph, 5HP Explosion Proof Motor, 1140RPM, 105DB'S, Medium Stand.		
USMSE-043	MCD48-10-M-3 EXP	48"Ø, 41000CFM, 230/460V, 28.9/14.5A, 3Ph, 10HP Explosion Proof Motor, 1140RPM, 105DB'S, Medium Stand.		

SEO Table of MCD Series Medium Stand Explosion Proof Industrial Direct Drive Blowers	
Title	
TPI MCD Series Medium Stand Explosion Proof Industrial Direct Drive Blowers.	
Meta Description	
TPI MCD Series Medium Stand Explosion Proof Industrial Direct Drive Blowers for Industrial Use, TPI MCD Series Medium Stand Explosion Proof Industrial Direct Drive Blowers for Commercial use, TPI MCD Series Medium Stand Explosion Proof Industrial Direct Drive Blowers for Indoor Use, TPI MCD Series Medium Stand Explosion Proof Industrial Direct Drive Blowers for Cooling Use, TPI MCD Series Medium Stand Explosion Proof Industrial Direct Drive Blowers for High Air Volume Movement Use, TPI MCD Series Medium Stand Explosion Proof Industrial Direct Drive Blowers for Ventilation Movement Use.	
Meta Key Words	
TPI MCD Series Medium Stand Explosion Proof Industrial Direct Drive Blowers for Industrial Use, TPI MCD Series Medium Stand Explosion Proof Industrial Direct Drive Blowers for Commercial use, TPI MCD Series Medium Stand Explosion Proof Industrial Direct Drive Blowers for Indoor Use, TPI MCD Series Medium Stand Explosion Proof Industrial Direct Drive Blowers for Cooling Use, TPI MCD Series Medium Stand Explosion Proof Industrial Direct Drive Blowers for High Air Volume Movement Use, TPI MCD Series Medium Stand Explosion Proof Industrial Direct Drive Blowers for Ventilation Movement Use.	
Meta URL (file name)	
tpi-mcd-series-medium-stand-explosion-proof-industrial-direct-drive-blowers-us-english.htm	

VentDepot.com

Ecological HVAC Supply & Engineering
1-888-514-1516, (626) 771-0048, F: (626) 771-0047
sales@ventdepot.com www.VentDepot.com



TPI Corporation
America's Comfort Conditioning Company

MCD Series
Medium Stand Explosion Proof
Industrial Heavy Duty
Direct Drive Blower
Data Sheet

Product Line Description of MCD Series Medium Stand Explosion Proof Industrial Direct Drive Blowers

Type: TPI MCD Series Medium Stand Explosion Proof Industrial Direct Drive Blowers

Drive Type: Direct Drive

Motor Type: Explosion Proof

Manufacturer: TPI

Model Series: MCD

Voltage: 115/230 or 230/460V

Horse Power: 1/4 to 10HP

Diameters: 18" to 48"

Air Flow: 3050 to 41000CFM

Ship By: Free LTL Freight

