

General Characteristics

The PurifyAir VentDepot, In-Ceiling Media Air Cleaner uses a three-speed direct-drive, forward-curve blower motor and a 95 percent DOP particle filter to capture airborne particles such as dust, soot, and cooking smoke from the air circulated through it.

D.O.P. particle filter is 95 percent efficient at 0.3 micron particles, and more efficient on both larger and smaller particles.

When equipped with two CPZ modules, the air cleaner also adsorbs gases and odors from the air passing through it.

Provides Coanda air distribution by drawing in dirty air, cleaning it, and bi-directionally recirculating the filtered air throughout the space.

Blower/Motor: Three-speed direct-drive forward curve. Motor lubrication is not required.

Easy to remove and replace filters.

Color: Galvanized steel cabinet and white cover.

Product Applications

It is used to Print Shops, offices, computer rooms, critical and healthcare facilities, spas and salons, funeral homes, casinos, restaurants, bingo halls & fraternal clubs, employee lounges, gyms and locker rooms, nursing homes, dental offices & labs, veterinary clinics hospital waiting rooms, energy savings applications, restrooms and more.

Warranty

Manufacturer's Limited Warranty: 1 Years.

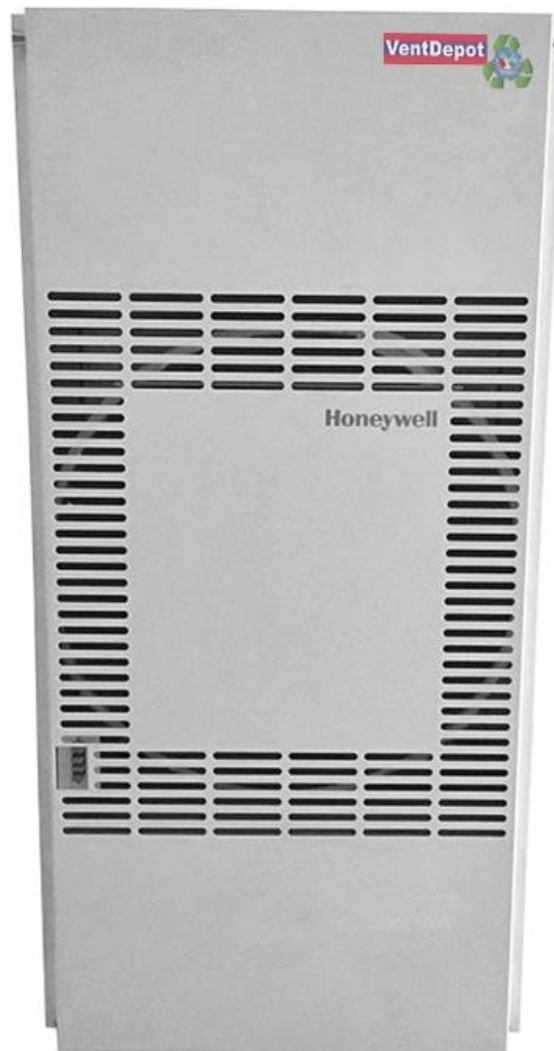

Specific characteristics of Ridge Roof Mounting Base CopperRidge

Item #	CMF	M ³ /HR	Volts V	HZ	A	SOUND LEVEL DBA	Filter	Weight and Dimension with Packaging	
								Lbs.	L,W,H In.
USPFA-001	425	723	120	60	2.8	65	95% AT 0.3 Micron	119	48,24,13



Dimensions (in)

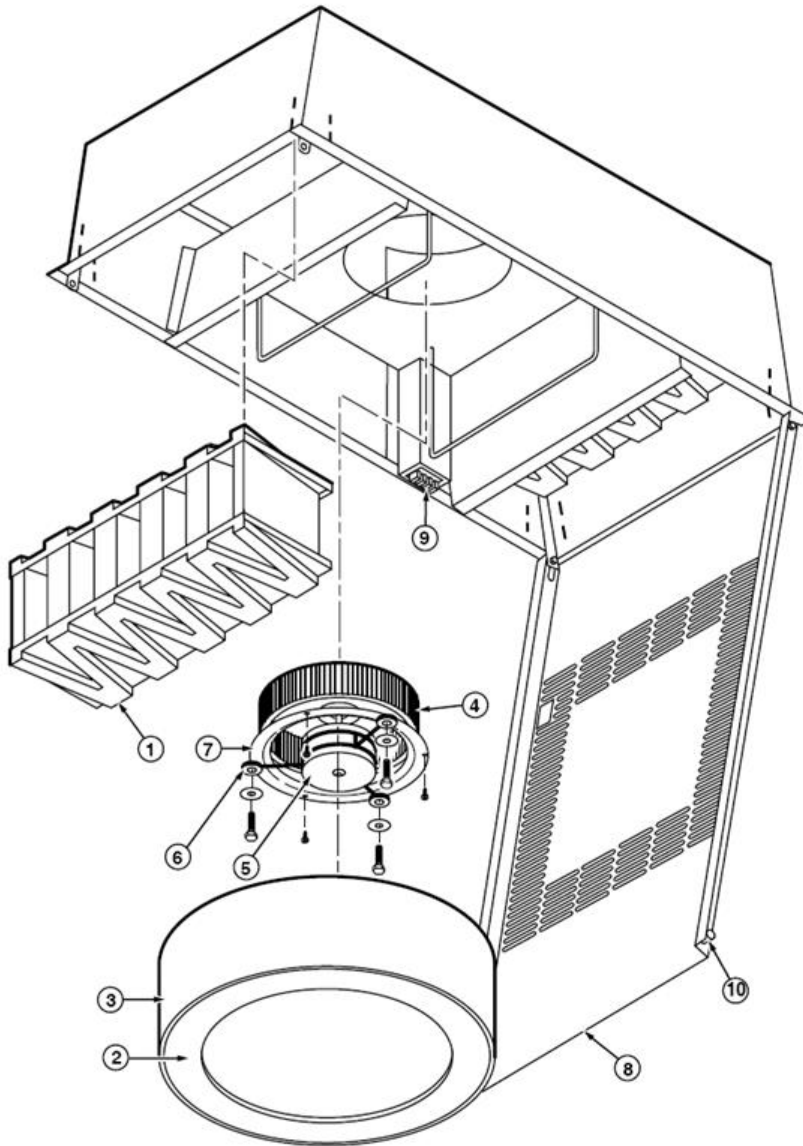

- 1 CPZ Sorbent Module (2) used only with DOP particle filters
- 2 DOP Primary Particle filter 95% (1)
- 3 Pre-filter (disposable)
- 4 Blower Wheel (1)
- 5 Motor Assembly (1)
- 6 Motor Mount
- 7 Inlet Cone
- 8 Grille assembly, without hinges and latches (1)
- 9 Speed Switch
- 10 Spring loaded plunger (2)