



**General Characteristics of EHB Series Explosion Proof Heavy Duty Belt Drive Exhaust Fan**

Used in industrial and commercial environments.  
 May be used indoors only unless they have protection from the elements.  
 The EHB Series are industrial fans designed for heavy duty use in anywhere large volumes of warm or stagnant air must be removed.  
 The TEC models are made with heavy gauge steel blades, and the EXP (explosion proof models) are made with cast aluminum blades.  
 Fans shipped completely assembled.  
 Designed with a 14 gauge steel panel with welded steel pipe bracing.  
 Totally enclosed and Explosion Proof Motors.  
 Explosion proof motors are class1, Div 1, Group D and class 2, div 1, Groups F & G.  
 Single motors are field convertible 115V/230V.  
 Three phase motors are field convertible 230V/460V.  
 For optimum shutter efficiency, mount shutter 1/3 the distance of the fan opening size. Example: 36" fan shutter would be mounted 12" from the fan blade.  
 Some options available include: CES shutters, EMF front guards, IBG rear guards, Acid resistant coating, Reversed air flow and Flat front vanturi.  
 All products listed in this section are custom built and subject to 100% cancellation/restocking charges.  
 Also depth dimension may vary with motor selection.



**Product Applications of EHB Series Explosion Proof Heavy Duty Belt Drive Exhaust Fan**

For industrial and commercial use  
 It is used to cool factories, shops, bakeries, loading docks, laundries, gymnasiums, warehouses, aircraft hangars, and virtually any place a high volume of air movement is required.  
 For removal of warm or stagnant air.  
 Can be used indoors or outdoors.

**Warranty of EHB Series Explosion Proof Heavy Duty Belt Drive Exhaust Fan**

Manufacturer's Limited Warranty: 1 Year.

**Specific Characteristics of EHB Series Explosion Proof Heavy Duty Belt Drive Exhaust Fan**

Item #	Manufacturing #	Blade Dia. (In.)	CFM	Volts V	Amperes A	Phases Ph	HP	RPM	Hertz Hz	Panel Size (Sq.)	Db's @10"	Weight and Dimensions with Packaging	
												Lbs.	L,W,H In.
<b>USETC-001</b>	EHB24-1/4	24	4900	115/230	2.25/1.13	1	1/4	780	60	30	60	102	18,32,32
<b>USETC-002</b>	EHB24-1/2	24	6219	115/230	4.5/2.25	1	1/2	980	60	30	66	132	18,32,32
<b>USETC-003</b>	EHB24-3/4	24	7090	115/230	6.76/3.38	1	3/4	1140	60	30	71	142	18,32,32
<b>USETC-004</b>	EHB24-1	24	7180	115/230	9.01/4.5	1	1	1250	60	30	73	142	18,32,32
<b>USETC-005</b>	EHB24-1/4-3	24	4900	230/460	0.73/0.36	3	1/4	780	60	30	60	102	18,32,32
<b>USETC-006</b>	EHB24-1/2-3	24	6219	230/460	1.45/0.73	3	1/2	980	60	30	66	132	18,32,32
<b>USETC-007</b>	EHB24-3/4-3	24	7090	230/460	2.16/1.09	3	3/4	1140	60	30	71	142	18,32,32
<b>USETC-008</b>	EHB24-1-3	24	7180	230/460	2.89/1.45	3	1	1250	60	30	73	142	18,32,32
<b>USETC-009</b>	EHB30-1/4	30	7178	115/230	2.25/1.13	1	1/4	540	60	36	61	142	18,38,38



**EHB Series**  
**Explosion Proof**  
**Heavy Duty Belt Drive**  
**Exhaust Fans**  
 Data sheet

Item #	Manufacturing #	Blade Dia. (In.)	CFM 0" SP	Volts V	Amperes A	Phases Ph	HP	RPM	Hertz Hz	Panel Size (Sq.)	Db's @10"	Weight and Dimensions with Packaging	
												Lbs.	L,W,H In.
USETC-010	EHB30-1/3	30	7909	115/230	2.97/1.49	1	1/3	595	60	36	63	152	18,38,38
USETC-011	EHB30-1/2	30	8507	115/230	4.5/2.25	1	1/2	640	60	36	64	157	18,38,38
USETC-012	EHB30-3/4	30	10235	115/230	6.76/3.38	1	3/4	770	60	36	66	167	18,38,38
USETC-013	EHB30-1	30	10668	115/230	9.01/4.5	1	1	975	60	36	70	172	18,38,38
USETC-014	EHB30-1 1/2	30	12473	115/230	13.5/6.76	1	1 1/2	1140	60	36	77	182	18,38,38
USETC-015	EHB30-1/4-3	30	7178	230/460	0.73/0.36	3	1/4	540	60	36	61	142	18,38,38
USETC-016	EHB30-1/33-	30	7909	230/460	0.95/0.48	3	1/3	595	60	36	63	152	18,38,38
USETC-017	EHB30-1/2-3	30	8507	230/460	1.45/0.73	3	1/2	640	60	36	64	157	18,38,38
USETC-018	EHB30-3/4-3	30	10235	230/460	2.16/1.09	3	3/4	770	60	36	66	167	18,38,38
USETC-019	EHB30-1-3	30	10668	230/460	2.89/1.45	3	1	975	60	36	70	172	18,38,38
USETC-020	EHB30-1 1/2-3	30	12473	230/460	4.34/2.16	3	1 1/2	1140	60	36	77	182	18,38,38
USETC-021	EHB36-1/3	36	9113	115/230	2.25/1.13	1	1/4	460	60	42	64	162	20,44,44
USETC-022	EHB36-1/2	36	10500	115/230	2.97/1.49	1	1/3	530	60	42	66	182	20,44,44
USETC-023	EHB36-3/4	36	11985	115/230	4.5/2.25	1	1/2	605	60	42	68	205	20,44,44
USETC-024	EHB36-1	36	13174	115/230	6.76/3.38	1	3/4	665	60	42	70	205	20,44,44
USETC-025	EHB36-1 1/2	36	13660	115/230	9.01/4.5	1	1	720	60	42	72	215	20,44,44
USETC-026	EHB36-1/3-3	36	9113	230/460	0.73/0.36	3	1/4	460	60	42	64	162	20,44,44
USETC-027	EHB36-1/2-3	36	10500	230/460	0.95/0.48	3	1/3	530	60	42	66	182	20,44,44
USETC-028	EHB36-3/4-3	36	11985	230/460	1.45/0.73	3	1/2	605	60	42	68	205	20,44,44
USETC-029	EHB36-1-3	36	13174	230/460	2.16/1.09	3	3/4	665	60	42	70	205	20,44,44
USETC-030	EHB36-1 1/2-3	36	13660	230/460	4.34/2.16	3	1 1/2	720	60	42	72	215	20,44,44
USETC-031	EHB36-2-3	36	16554	230/460	5.78/2.89	3	2	870	60	42	74	220	20,44,44
USETC-032	EHB42-1/3	42	10614	115/230	2.97/1.49	1	1/3	335	60	48	64	210	22,50,50
USETC-033	EHB42-1/2	42	12343	115/230	4.5/2.25	1	1/2	390	60	48	65	215	22,50,50
USETC-034	EHB42-3/4	42	14040	115/230	6.76/3.38	1	3/4	435	60	48	67	230	22,50,50
USETC-035	EHB42-1	42	15429	115/230	9.01/4.5	1	1	490	60	48	69	235	22,50,50
USETC-036	EHB42-1 1/2	42	17420	115/230	13.5/6.76	1	1 1/2	550	60	48	71	254	22,50,50
USETC-037	EHB42-1/3-3	42	10614	230/460	0.95/0.48	3	1/3	335	60	48	64	210	22,50,50
USETC-038	EHB42-1/2-3	42	12343	230/460	1.45/0.73	3	1/2	390	60	48	65	215	22,50,50
USETC-039	EHB42-3/4-3	42	14040	230/460	2.16/1.09	3	3/4	435	60	48	67	230	22,50,50
USETC-040	EHB42-1-3	42	15429	230/460	2.89/1.45	3	1	490	60	48	69	235	22,50,50
USETC-041	EHB42-1 1/2-3	42	17420	230/460	4.34/2.16	3	1 1/2	550	60	48	71	254	22,50,50
USETC-042	EHB42-2-3	42	20653	230/460	5.78/2.89	3	2	725	60	48	74	250	22,50,50
USETC-043	EHB42-3-3	42	23645	230/460	8.68/4.34	3	3	830	60	48	79	255	22,50,50
USETC-044	EHB48-1/2	48	15230	115/230	4.5/2.25	1	1/2	330	60	54	69	192	23,56,56
USETC-045	EHB48-3/4	48	17339	115/230	6.76/3.38	1	3/4	370	60	54	70	197	23,56,56
USETC-046	EHB48-1	48	19188	115/230	9.01/4.5	1	1	410	60	54	71	240	23,56,56
USETC-047	EHB48-1 1/2	48	21731	115/230	13.5/6.76	1	1 1/2	465	60	54	72	250	23,56,56
USETC-048	EHB48-1/2-3	48	15230	230/460	1.45/0.73	3	1/2	330	60	54	69	192	23,56,56
USETC-049	EHB48-3/4-3	48	17339	230/460	2.16/1.09	3	3/4	370	60	54	70	197	23,56,56
USETC-050	EHB48-1-3	48	19188	230/460	2.89/1.45	3	1	410	60	54	71	240	23,56,56
USETC-051	EHB24-1 1/2-3	48	21731	230/460	4.34/2.16	3	1 1/2	465	60	54	72	250	23,56,56
USETC-052	EHB48-2-3	48	24274	230/460	5.78/2.89	1	2	520	60	54	74	255	23,56,56
USETC-053	EHB48-3-3	48	28150	230/460	13.5/6.76	1	3	680	60	54	80	275	23,56,56
USETC-054	EHB48-5-3	48	33160	230/460	22.5/11.3	1	5	800	60	54	83	290	23,56,56
USETC-055	EHB60-1	60	23090	115/230	9.01/4.5	1	1	280	60	66	76	385	28,68,68
USETC-056	EHB60-1 1/2	60	28068	115/230	13.5/6.76	1	1 1/2	340	60	66	77	395	28,68,68
USETC-057	EHB60-1-3	60	23090	230/460	2.89/1.45	3	1	280	60	66	76	385	28,68,68
USETC-058	EHB60-1 1/2-3	60	28068	230/460	4.34/2.16	3	1 1/2	340	60	66	77	395	28,68,68



**EHB Series  
 Explosion Proof  
 Heavy Duty Belt Drive  
 Exhaust Fans**  
 Data sheet

Item #	Manufacturing #	Blade Dia. (In.)	CFM 0" SP	Volts V	Amperes A	Phases Ph	HP	RPM	Hertz Hz	Panel Size (Sq.)	Db's @10"	Weight and Dimensions with Packaging	
												Lbs.	L,W,H In.
<b>USETC-059</b>	EHB60-2-3	60	32200	230/460	5.78/2.89	3	2	390	60	66	78	400	28,68,68
<b>USETC-060</b>	EHB60-3-3	60	37183	230/460	8.68/4.34	3	3	450	60	66	84	415	28,68,68
<b>USETC-061</b>	EHB60-5-3	60	44600	230/460	14.5/7.23	3	5	540	60	66	86	425	28,68,68

**Dimensions (In.) of EHB Series Explosion Proof Heavy Duty Belt Drive Exhaust Fan**

Series	Length		Width		Height C
	A	B	B	C	
USETC-001 to 008	16"	30"	30"	16"	
USETC-009 to 020	16"	36"	36"	16"	
USETC-021 to 031	18"	42"	42"	18"	
USETC-032 to 043	20"	48"	48"	20"	
USETC-044 to 054	21"	54"	54"	54"	
USETC-055 to 061	26"	66"	66"	66"	

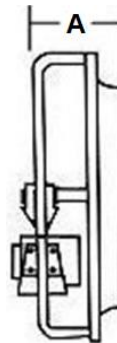
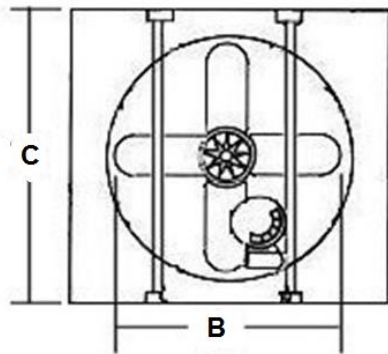



## EHB Series Explosion Proof Heavy Duty Belt Drive Exhaust Fan

### Ratings Definitions

**Class I:** Equipment does not have surface operating temperature in excess of the ignition temperature of the specific gas or vapor.

Application Examples:

- Offshore and land based drilling rigs, petroleum exploration and testing facilities.
- Petroleum refineries, gasoline storage and dispensing areas.
- Industrial firms that use flammable liquids in dip tanks for parts cleaning or other operations.
- Petrochemical companies that manufacture chemicals from gas or oil.
- Dry cleaning facilities where vapors from cleaning fluids may be present.
- Aircraft hangers and fuel servicing areas.
- Utility gas plants and operations involving storage and handling of liquefied petroleum or natural gas.

**Group C:** Atmospheres such as but not limited to acetaldehyde, allyl alcohol, hydrogen sulfide, ethylene, carbon monoxide, or other gases or vapors of equivalent hazard.

**Group D:** Atmospheres such as but not limited to acetone, alcohol, gasoline, lacquer solvent vapors, natural gas, propane or other gases or vapors of equivalent hazard.

**Class II:** Equipment does not have surface temperature greater than the ignition temperature of the specified dust.

Application Examples:

- Coal preparation plants and other carbon handling or processing areas.
- Grain elevators, flour and feed mills.
- Plants which manufacture, use or store Magnesium or Aluminum powders.
- Plants that have chemical or metallurgical processes.
- Producers of starch products or candy.
- Spice grinding plants, sugar plants and cocoa plants.

**Group E:** Atmosphere containing combustible metal dust regardless of resistivity, or other combustible dust of similar hazard characteristics having resistivity of less than  $10^5$  OHM- centimeter.

**Group F:** Atmosphere containing carbon black, charcoal, coal or coke dust.

**Group G:** Atmospheres containing combustible dust having resistivity of  $10^5$  OHM- centimeter or greater.

**Division I:** A location in which ignitable concentrations of flammable material exist under normal operating conditions.

**Division II:** Locations in which flammable materials will normally be confined within closed containers and escape only in the case of accidental rupture, breakdown or during maintenance operations. Any equipment approved for Division I is automatically also approved for Division II.



**Short Description of EHB Series Explosion Proof Heavy Duty Belt Drive Exhaust Fan**

Item #	Manufacturing #	Short Description 70 Characters Maximum
		0123456789012345678901234567890123456789012345678901234567890123456789
<b>USETC-001</b>	EHB24-1/4	24", 4900CFM, 115/230V, 2.25/1.13A, 1PH, 1/4HP, 780RPM, 60HZ, Panel 30", 60dB's.

**SEO Table of EHB Series Explosion Proof Heavy Duty Belt Drive Exhaust Fan**

Title
TPI EHB Series Heavy Duty Belt Drive Exhaust Fans.
Meta Description
TPI EHB Series Heavy Duty Belt Drive Exhaust Fans for Industrial Use, TPI EHB Series Heavy Duty Belt Drive Exhaust Fans for Commercial use, TPI EHB Series Heavy Duty Belt Drive Exhaust Fans for Residential Use, TPI EHB Series Heavy Duty Belt Drive Exhaust Fans for Indoor Use, TPI EHB Series Heavy Duty Belt Drive Exhaust Fans for Cooling Use, TPI EHB Series Heavy Duty Belt Drive Exhaust Fans For High Air Volume Movement Use, TPI EHB Series Heavy Duty Belt Drive Exhaust Fans For Removal of Warm Air Use, TPI EHB Series Heavy Duty Belt Drive Exhaust Fans For Removal of Stagnant Air Use.
Meta Key Words
TPI EHB Series Heavy Duty Belt Drive Exhaust Fans for Industrial Use, TPI EHB Series Heavy Duty Belt Drive Exhaust Fans for Commercial use, TPI EHB Series Heavy Duty Belt Drive Exhaust Fans for Residential Use, TPI EHB Series Heavy Duty Belt Drive Exhaust Fans for Indoor Use, TPI EHB Series Heavy Duty Belt Drive Exhaust Fans for Cooling Use, TPI EHB Series Heavy Duty Belt Drive Exhaust Fans For High Air Volume Movement Use, TPI EHB Series Heavy Duty Belt Drive Exhaust Fans For Removal of Warm Air Use, TPI EHB Series Heavy Duty Belt Drive Exhaust Fans For Removal of Stagnant Air Use.
Meta URL (file name)
Tpi-ehb-series-heavy-duty-belt-drive-exhaust-fans-us-english.htm

**Product Line Description of EHB Series Explosion Proof Heavy Duty Belt Drive Exhaust Fan**

<FONT Size=1> <b>Type:</b> TPI EHB Series Heavy Duty Belt Drive Exhaust Fans  <b>Drive Type:</b> Belt Drive  <b>Motor Type:</b> Explosion Proof  <b>Manufacturer:</b> TPI  <b>Model Series:</b> EHB  <b>Voltage:</b> 115/230 or 230/460V  <b>Horse Power:</b> 1/4, 1/2, 3/4, 1, 2, 3 & 5Hp  <b>Diameters:</b> 24", 30", 36", 42", 48" & 60"  <b>Air Flow:</b> 4900 to 23645  <b>Weather Rating:</b> Indoor  <b>Ship By:</b> Free LTL Freight  </FONT>
--