

General Characteristics of Copper Turbine EmpiCop

The VentDepot EmpiCop is a dependable copper rotary turbine which works automatically, continuously and silently without operating or maintenance costs. Outside braced for strength, safety, and perfect alignment. Ventilators up to and including 14" are copper braced. Larger sizes are steel braced for additional strength. Operation is simple and sure. When the slightest breeze touches the aerodynamic blade construction it causes the turbine to rotate. The centrifugal force caused by the revolving turbine creates a partial vacuum within the turbine. This vacuum is then replaced by a strong upward draft of air. A powerful exhaust is thus achieved. Built with Grease Trap Bearings The lower thrust bearing is a hardened steel ball riding in a hardened steel concave seat (in sizes up to 8") for extreme sensitivity and wearability. Upper bearings on all ventilators are bronze oil-less. The rigid construction of these stormproof ventilators assures years of efficient service. No adjusting or servicing is required. Bases Not Included.



Application of Copper Turbine EmpiCop

Removes heat, vapor, gasses, odors, smoke, solvents, and humidity
 Used for: ventilation in small and large areas, exhaust pipes, bathrooms, warehouses, factories, commercial buildings, and all large projects of ventilation. The turbine can operate up to temperatures of 150°F.

Warranty of Copper Turbine EmpiCop

Manufacturer's Limited Warranty: 3 Years

Technical Characteristics of Copper Turbine EmpiCop

Item #	Manufacturer #	Dimensions		Cubic feet per minute at 90°F internal temperature and 90°F external temperature		Material	Included Base *	Weight and Shipping Size	
		Ø mm	Ø in	CFM	m³/hr			Lbs.	In.
USECO-001	TV04C	100	4	82	139	Copper	No	4	9,11,9
USECO-002	TV05C	127	5	133	226	Copper	No	5	11,13,11
USECO-003	TV06C	152	6	195	331	Copper	No	5	13,15,13
USECO-004	TV07C	178	7	256	435	Copper	No	6	15,17,15
USECO-005	TV08C	203	8	338	574	Copper	No	6	17,19,17
USECO-006	TV09C	228	9	431	732	Copper	No	8	19,20,19
USECO-007	TV10C	254	10	631	1072	Copper	No	8	20,22,20

Item #	Manufacturer #	Dimensions		Cubic feet per minute at 90°F internal temperature and 90°F external temperature		Material	Included Base	Weight and Shipping Size	
		Ø mm	Ø in	CFM	m³/hr			Lbs.	In.
USECO-008	TV12C	305	12	883	1501	Copper	No	9.5	24,26,24
USECO-009	TV14C	355	14	1129	1919	Copper	No	15	28,31,28
USECO-010	TV16C	406	16	1304	2216	Copper	No	23	33,35,33
USECO-011	TV18C	457	18	1623	2759	Copper	No	29	36,38,36
USECO-012	TV20C	508	20	1951	3316	Copper	No	34	40,42,40
USECO-013	TV24C	609	24	2824	4800	Copper	No	45	48,50,48

*Bases not included. Style, material and/or pitch must be determined by the client.

Dimensions (mm. & In.) of Copper Turbine EmpiCop

Item #	A		B		C	
	mm.	In.	mm.	In.	mm.	In.
USECO-001	101	4	254	10	203	8
USECO-002	127	5	305	12	254	10
USECO-003	152	6	355	14	305	12
USECO-004	178	7	406	16	355	14
USECO-005	203	8	457	18	406	16
USECO-006	228	9	509	20	457	18
USECO-007	254	10	559	22	508	20
USECO-008	305	12	660	26	609	24
USECO-009	355	14	762	30	711	28
USECO-010	406	16	863	34	813	32
USECO-011	457	18	965	38	914	38
USECO-012	508	20	1066	42	1016	40
USECO-013	609	24	1270	50	1219	48

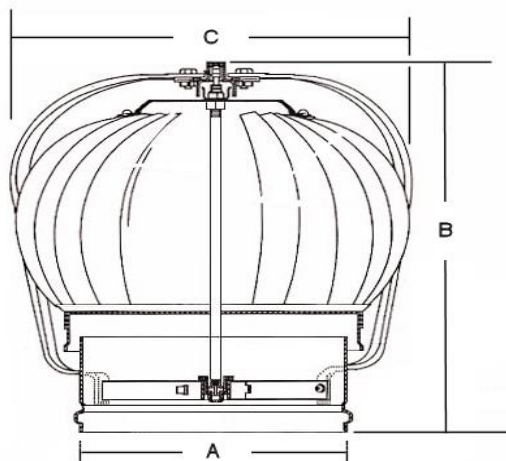

Functionality of Copper Turbine EmpiCop



- ▶ Begins working with wind as low as 1.5MPH
- ▶ The EmpiCop is so quiet and operates at the slightest breeze. When others barely start to operate the TurboVent already did the job..



- ▶ It also operates with a heat differential of 5°F.
- ▶ It has a super flow effect when other intakes and fan injectors are present.

CFM Calculation Formula by Wind Velocity and Temperature of Copper Turbine EmpiCop

▶ **CFM** (Cubic Feet per Minute of air removal) for the EmpiCop In the following, choose the appropriate formula:

USECO-001 Use the following:

$$CFM^* = 0.5899 [0.818 + (0.00923 (H)) \{ [121.5 + 173.6 (V)] + 6.4444(Tint - Text) + 3.111(Text-32) \} (0.08)$$

USECO-002 Use the following:

$$CFM^* = 0.5899 [0.818 + (0.00923 (H)) \{ [121.5 + 173.6 (V)] + 6.4444(Tint - Text) + 3.111(Text-32) \} (0.13)$$

USECO-003 Use the following:

$$CFM^* = 0.5899 [0.818 + (0.00923 (H)) \{ [121.5 + 173.6 (V)] + 6.4444(Tint - Text) + 3.111(Text-32) \} (0.19)$$

USECO-004 Use the following:

$$CFM^* = 0.5899 [0.818 + (0.00923 (H)) \{ [121.5 + 173.6 (V)] + 6.4444(Tint - Text) + 3.111(Text-32) \} (0.25)$$

USECO-005 Use the following:

$$CFM^* = 0.5899 [0.818 + (0.00923 (H)) \{ [121.5 + 173.6 (V)] + 6.4444(Tint - Text) + 3.111(Text-32) \} (0.33)$$

USECO-006 Use the following:

$$CFM^* = 0.5899 [0.818 + (0.00923 (H)) \{ [121.5 + 173.6 (V)] + 6.4444(Tint - Text) + 3.111(Text-32) \} (0.42)$$

USECO-007 Use the following:

$$CFM^* = 0.5899 [0.818 + (0.00923 (H)) \{ [121.5 + 173.6 (V)] + 6.4444(Tint - Text) + 3.111(Text-32) \} (0.51)$$

USECO-008 Use the following:

$$CFM^* = 0.5899 [0.818 + (0.00923 (H)) \{ [121.5 + 173.6 (V)] + 6.4444(Tint - Text) + 3.111(Text-32) \} (0.86)$$

CFM Calculation Formula by Wind Velocity and Temperature of Copper Turbine EmpiCop

USECO-009 Use the following:

$$CFM^* = 0.5899 [0.818 + (0.00923 (H)) \{ [121.5 + 173.6 (V)] + 6.4444(Tint - Text) + 3.111(Text-32) \}] (1.10)$$

USECO-010 Use the following:

$$CFM^* = 0.5899 [0.818 + (0.00923 (H)) \{ [121.5 + 173.6 (V)] + 6.4444(Tint - Text) + 3.111(Text-32) \}] (1.27)$$

USECO-011 Use the following:

$$CFM^* = 0.5899 [0.818 + (0.00923 (H)) \{ [121.5 + 173.6 (V)] + 6.4444(Tint - Text) + 3.111(Text-32) \}] (1.58)$$

USECO-012 Use the following:

$$CFM^* = 0.5899 [0.818 + (0.00923 (H)) \{ [121.5 + 173.6 (V)] + 6.4444(Tint - Text) + 3.111(Text-32) \}] (1.90)$$

USECO-013 Use the following:

$$CFM^* = 0.5899 [0.818 + (0.00923 (H)) \{ [121.5 + 173.6 (V)] + 6.4444(Tint - Text) + 3.111(Text-32) \}] (2.75)$$

H= Height in feet from the floor where the TurboVent will be located

V= Wind Velocity in MPH (Miles per Hour)

Tint=Temperature in degrees Fahrenheit Inside the attic or place to ventilate

Text=Temperature in degrees Fahrenheit Outside the building, yearly average or average high, whichever is higher

EmpiCop, Overview

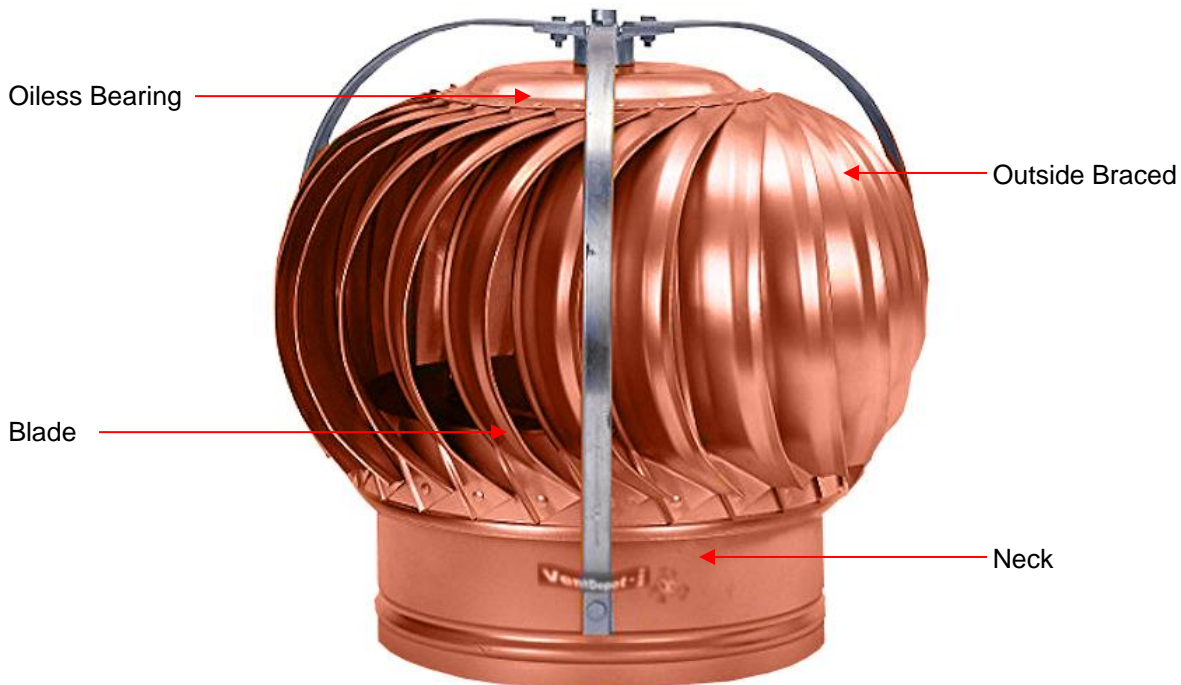

EmpiCop, Top view

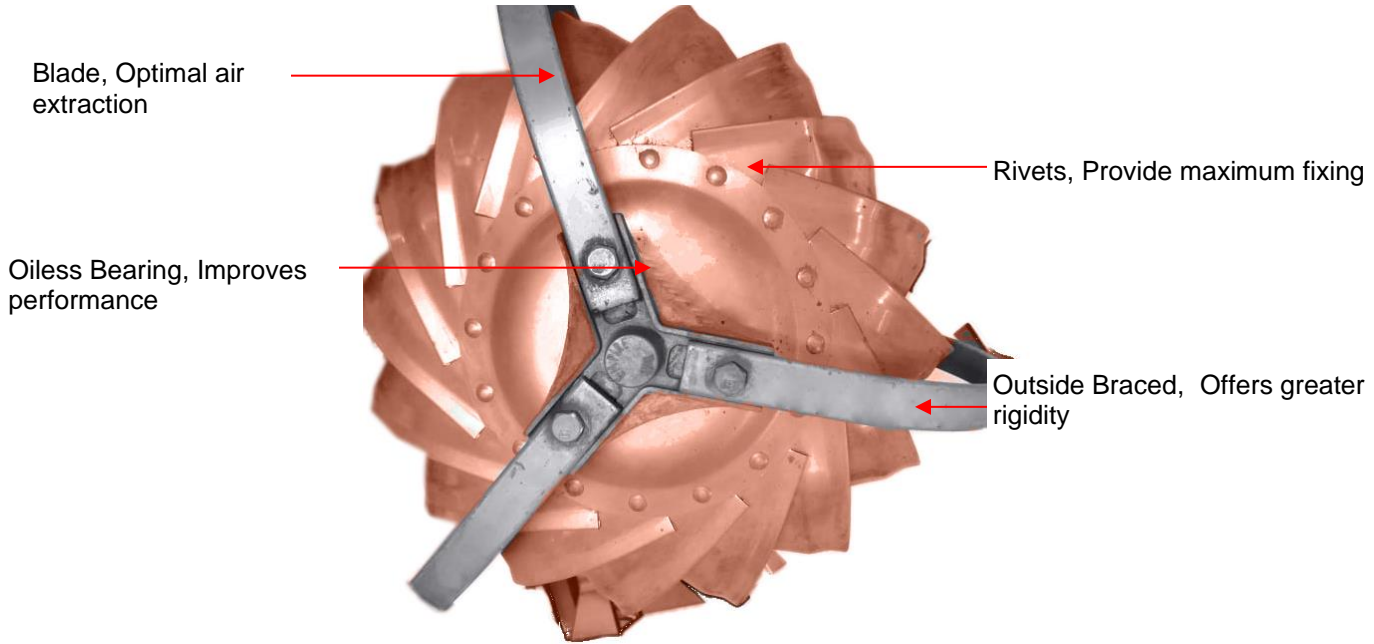

EmpiCop, Top Detailed view

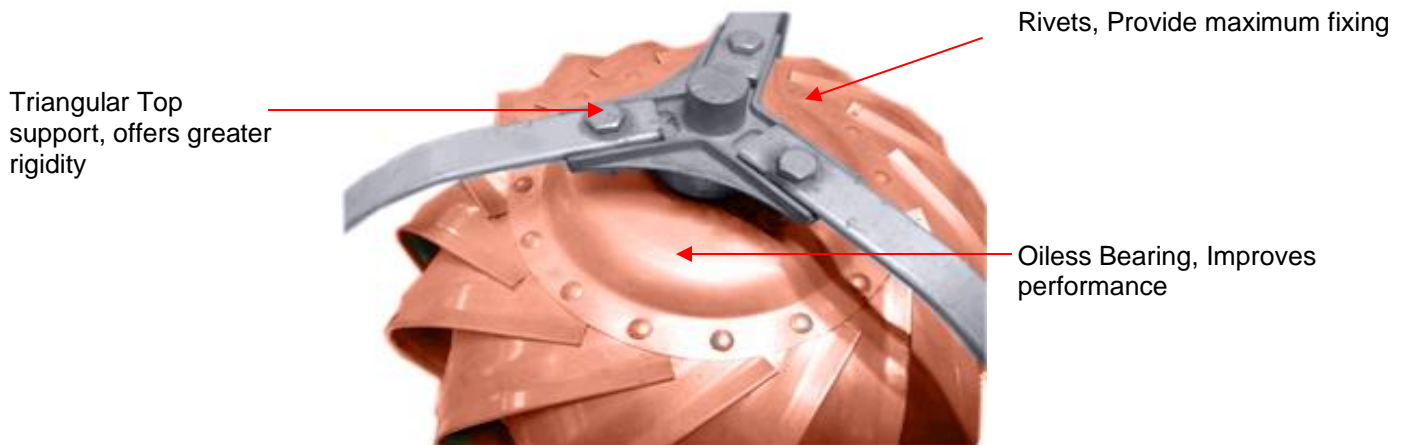

EmpiCop, Bottom view

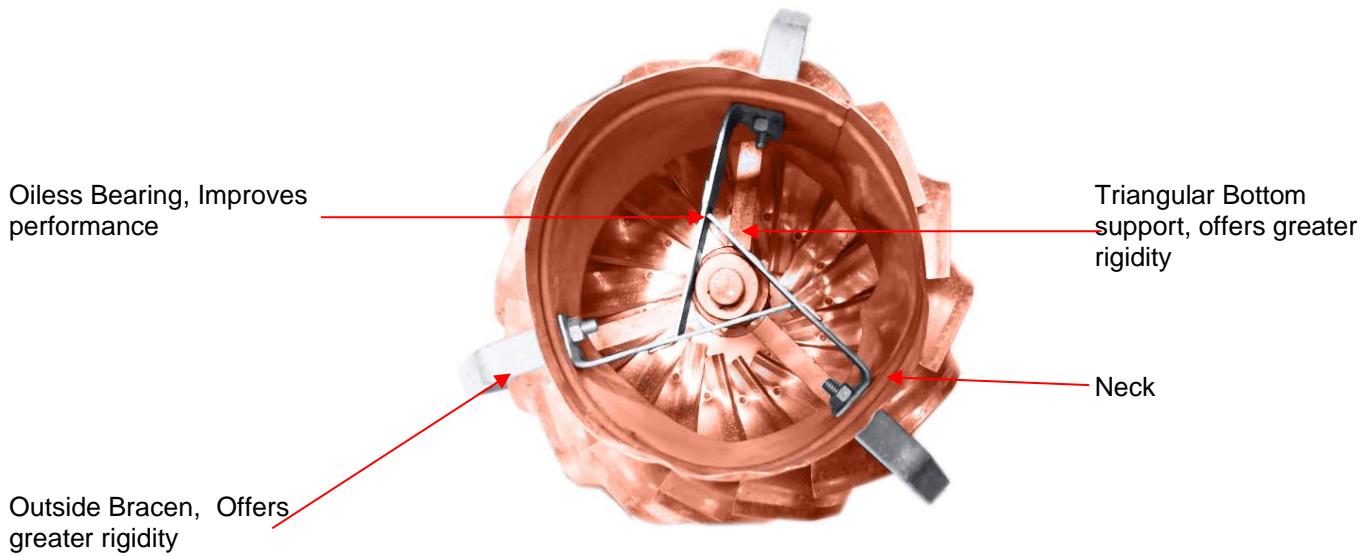

EmpiCop, Bottom detailed view

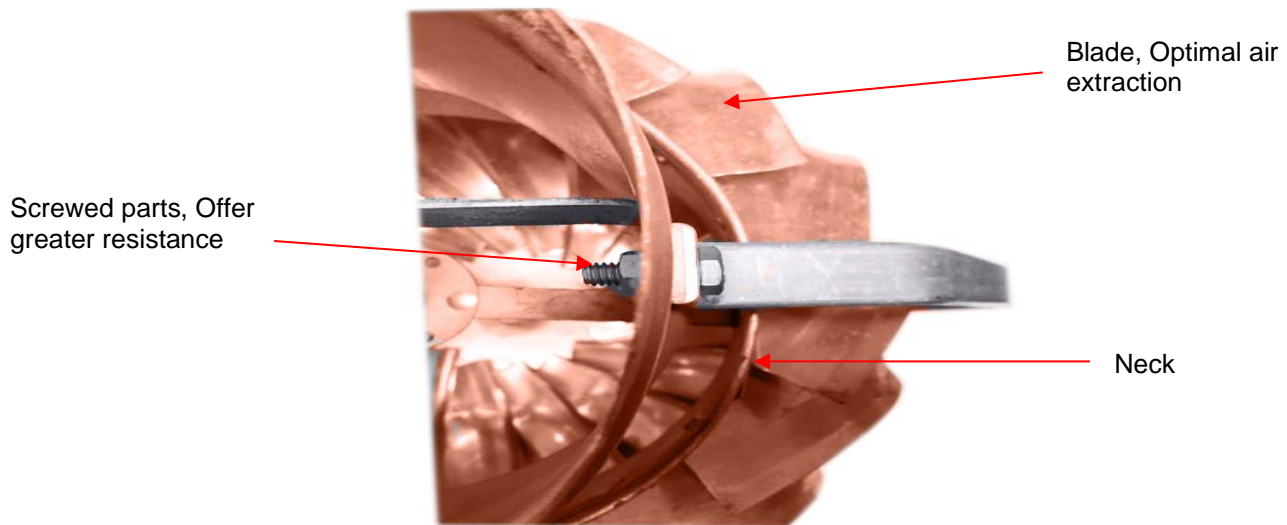

Following are tables with the CFM calculated for typical wind velocities and temperatures

4" diameter EmpiCop USECO-001 Tint 80°F

		Tint °F	80	80	80	80	80	80	80	80	
		Text °F	60	65	70	75	80	85	90	95	100
V MPH	2	33*	32	31	30	30	29	28	27	26	
	4	50	49	48	47	46	46	45	44	43	
	6	67	66	65	64	63	62	62	61	60	
	8	83	83	82	81	80	79	79	78	77	
	10	100	99	99	98	98	96	95	95	94	
	12	117	116	116	115	114	113	112	111	111	
	14	134	133	132	132	131	130	129	128	128	

* CFM (Cubic Feet per Minute)

EmpiCop USECO-001 Tint 90°F

		Tint °F	90	90	90	90	90	90	90	90	
		Text °F	60	65	70	75	80	85	90	95	100
V MPH	2	36*	35	34	33	33	32	31	30	29	
	4	53	52	51	50	50	49	48	47	46	
	6	70	69	68	67	66	66	65	64	63	
	8	87	86	85	84	83	82	82	81	80	
	10	103	103	102	101	100	99	99	98	97	
	12	120	119	119	118	117	116	115	115	114	
	14	137	136	136	135	134	133	132	131	131	

* CFM (Cubic Feet per Minute)

EmpiCop USECO-001 Tint 100°F

		Tint °F	100	100	100	100	100	100	100	100	
		Text °F	60	65	70	75	80	85	90	95	100
V MPH	2	39*	38	37	37	36	35	34	33	33	
	4	56	55	54	53	53	52	51	50	49	
	6	73	72	71	70	70	69	68	67	66	
	8	90	89	88	87	86	86	85	84	83	
	10	107	106	105	104	103	102	102	101	100	
	12	123	123	122	121	120	119	119	118	117	
	14	140	139	139	138	137	136	135	135	134	

* CFM (Cubic Feet per Minute)

EmpiCop USECO-001 Tint 110°F

		Tint °F	110	110	110	110	110	110	110	110	
		Text °F	60	65	70	75	80	85	90	95	100
V MPH	2	42*	41	41	40	39	38	37	37	36	
	4	59	58	57	57	56	55	54	53	53	
	6	76	75	74	73	73	72	71	70	69	
	8	93	92	91	90	90	89	88	87	86	
	10	110	109	108	107	106	106	105	104	103	
	12	127	126	125	124	123	123	122	121	120	
	14	143	143	142	141	140	139	139	138	137	

* CFM (Cubic Feet per Minute)

5" diameter EmpiCOP USECO-002 Tint 80°F

		Tint °F	80	80	80	80	80	80	80	80	
		Text °F	60	65	70	75	80	85	90	95	100
V MPH	2	54*	52	51	50	48	47	46	44	43	
	4	81	80	78	77	76	74	73	72	70	
	6	108	107	106	104	103	102	101	99	98	
	8	136	135	133	132	131	129	128	127	125	
	10	163	162	161	159	158	157	155	154	153	
	12	191	189	188	187	185	184	183	181	180	
	14	218	217	215	214	213	212	210	209	208	

* CFM (Cubic Feet per Minute)

EmpiCOP USECO-002 Tint 90°F

		Tint °F	90	90	90	90	90	90	90	90	
		Text °F	60	65	70	75	80	85	90	95	100
V MPH	2	59*	57	56	55	53	52	51	49	48	
	4	86	85	83	82	81	80	78	77	76	
	6	114	112	111	110	108	107	106	104	103	
	8	141	140	138	137	136	134	133	132	130	
	10	168	167	166	164	163	162	160	159	158	
	12	196	194	193	192	191	189	188	187	185	
	14	223	222	221	219	218	217	215	214	213	

* CFM (Cubic Feet per Minute)

EmpiCOP USECO-002 Tint 100°F

		Tint °F	100	100	100	100	100	100	100	100	
		Text °F	60	65	70	75	80	85	90	95	100
V MPH	2	64*	62	61	60	58	57	56	55	53	
	4	91	90	89	87	86	85	83	82	81	
	6	119	117	116	115	113	112	111	109	108	
	8	146	145	143	142	141	139	138	137	136	
	10	173	172	171	170	168	167	166	164	163	
	12	201	200	198	197	196	194	193	192	190	
	14	228	227	226	224	223	222	220	219	218	

* CFM (Cubic Feet per Minute)

EmpiCOP USECO-002 Tint 110°F

		Tint °F	110	110	110	110	110	110	110	110	
		Text °F	60	65	70	75	80	85	90	95	100
V MPH	2	69*	68	66	65	64	62	61	60	58	
	4	96	95	94	92	91	90	88	87	86	
	6	124	122	121	120	118	117	116	114	113	
	8	151	150	148	147	146	145	143	142	141	
	10	179	177	176	175	173	172	171	169	168	
	12	206	205	203	202	201	199	198	197	195	
	14	233	232	231	229	228	227	225	224	223	

* CFM (Cubic Feet per Minute)

6" diameter EmpiCOP USECO-003 Tint 80°F

	Tint °F	80	80	80	80	80	80	80	80	80
	Text °F	60	65	70	75	80	85	90	95	100
V MPH	2	79*	77	75	77	71	69	67	65	63
	4	119	117	115	113	111	109	107	105	103
	6	159	157	155	153	151	149	147	145	143
	8	199	197	195	193	191	189	187	185	183
	10	239	237	235	233	231	229	227	225	223
	12	279	277	275	273	271	269	267	265	264
	14	319	317	315	313	311	309	307	306	304

* CFM (Cubic Feet per Minute)

EmpiCOP USECO-003 Tint 90°F

	Tint °F	90	90	90	90	90	90	90	90	90
	Text °F	60	65	70	75	80	85	90	95	100
V MPH	2	86*	84	82	80	78	76	74	73	71
	4	126	124	122	120	118	116	115	113	111
	6	166	164	162	160	158	157	155	153	151
	8	206	204	202	200	199	197	195	193	191
	10	246	244	242	241	239	237	235	233	231
	12	286	284	283	291	279	277	275	273	271
	14	326	325	323	321	319	317	315	313	311

* CFM (Cubic Feet per Minute)

EmpiCOP USECO-003 Tint 100°F

	Tint °F	100	100	100	100	100	100	100	100	100
	Text °F	60	65	70	75	80	85	90	95	100
V MPH	2	93*	91	90	88	86	84	82	80	78
	4	134	132	130	128	126	124	122	120	118
	6	174	172	170	168	166	164	162	160	158
	8	214	212	210	208	206	204	202	200	198
	10	254	252	250	248	246	244	242	240	238
	12	294	292	290	288	286	284	282	280	278
	14	334	332	330	328	326	324	322	320	319

* CFM (Cubic Feet per Minute)

EmpiCOP USECO-003 Tint 110°F

	Tint °F	110	110	110	110	110	110	110	110	110
	Text °F	60	65	70	75	80	85	90	95	100
V MPH	2	101*	99	97	95	93	91	89	87	85
	4	141	139	137	135	133	131	129	127	126
	6	181	179	177	175	173	171	169	168	166
	8	221	219	217	215	213	211	210	208	206
	10	261	259	257	255	253	252	250	248	246
	12	301	299	297	295	294	292	290	288	286
	14	341	339	337	336	334	332	330	328	326

* CFM (Cubic Feet per Minute)

7" diameter EmpiCOP USECO-004 Tint 80°F

	Tint °F	80	80	80	80	80	80	80	80	80
	Text °F	60	65	70	75	80	85	90	95	100
V MPH	2	104*	101	98	96	93	91	88	86	83
	4	156	154	151	149	146	144	141	139	136
	6	209	206	204	201	199	196	194	191	189
	8	262	259	257	254	252	249	247	244	241
	10	314	312	309	307	304	302	299	297	294
	12	367	365	362	360	410	355	352	349	347
	14	420	417	415	412	410	407	405	402	400

* CFM (Cubic Feet per Minute)

EmpiCOP USECO-004 Tint 90°F

	Tint °F	90	90	90	90	90	90	90	90	90
	Text °F	60	65	70	75	80	85	90	95	100
V MPH	2	113*	111	108	106	103	101	98	96	93
	4	166	163	161	159	156	153	151	148	146
	6	219	216	214	211	209	206	204	201	199
	8	272	269	266	264	261	259	256	254	251
	10	324	322	319	317	314	312	309	307	304
	12	377	374	372	369	367	364	362	359	357
	14	430	427	425	422	420	417	415	412	409

* CFM (Cubic Feet per Minute)

EmpiCOP USECO-004 Tint 100°F

	Tint °F	100	100	100	100	100	100	100	100	100
	Text °F	60	65	70	75	80	85	90	95	100
V MPH	2	123*	121	118	115	113	110	108	105	103
	4	176	173	171	169	166	163	161	158	156
	6	229	226	223	221	218	216	213	211	208
	8	281	279	276	274	271	269	266	264	261
	10	334	332	329	326	324	321	319	316	314
	12	387	384	382	379	377	374	372	369	367
	14	440	437	434	432	429	427	424	422	419

* CFM (Cubic Feet per Minute)

EmpiCOP USECO-004 Tint 110°F

	Tint °F	110	110	110	110	110	110	110	110	110
	Text °F	60	65	70	75	80	85	90	95	100
V MPH	2	133*	130	128	125	123	120	118	115	113
	4	186	183	181	178	175	173	170	168	165
	6	238	236	233	231	228	226	223	221	218
	8	291	289	286	283	281	278	276	273	271
	10	344	341	339	336	334	331	329	326	324
	12	397	394	391	389	386	384	381	379	376
	14	449	447	444	442	439	437	434	432	429

* CFM (Cubic Feet per Minute)

8" diameter EmpiCOP USECO-005 Tint 80°F

		Tint °F	80	80	80	80	80	80	80	80	
		Text °F	60	65	70	75	80	85	90	95	100
V MPH	2		137*	133	130	127	123	120	117	113	110
	4		206	203	200	196	193	190	186	183	180
	6		276	273	269	266	263	259	256	253	249
	8		346	342	339	336	332	329	326	322	319
	10		415	412	409	405	402	399	395	392	389
	12		485	482	478	475	471	468	465	461	458
	14		554	551	548	544	541	538	534	531	528

* CFM (Cubic Feet per Minute)

EmpiCop USECO-005 Tint 90°F

		Tint °F	90	90	90	90	90	90	90	90	
		Text °F	60	65	70	75	80	85	90	95	100
V MPH	2		150*	146	143	140	136	133	126	128	123
	4		219	216	213	209	206	203	199	196	193
	6		289	286	282	279	276	272	269	266	262
	8		359	355	352	349	345	342	338	335	332
	10		428	425	421	418	415	411	408	405	401
	12		498	494	491	488	484	481	478	474	471
	14		567	564	561	557	554	551	547	544	541

* CFM (Cubic Feet per Minute)

EmpiCop USECO-005 Tint 100°F

		Tint °F	100	100	100	100	100	100	100	100	
		Text °F	60	65	70	75	80	85	90	95	100
V MPH	2		163*	159	156	153	149	146	143	139	136
	4		232	229	226	222	219	216	212	209	206
	6		302	299	295	292	288	285	282	278	275
	8		371	368	365	361	358	355	351	348	345
	10		441	438	434	431	428	424	421	418	414
	12		511	507	504	501	497	494	491	487	484
	14		580	577	574	570	567	564	560	557	554

* CFM (Cubic Feet per Minute)

EmpiCop USECO-005 Tint 110°F

		Tint °F	110	110	110	110	110	110	110	110	
		Text °F	60	65	70	75	80	85	90	95	100
V MPH	2		176*	172	169	166	162	159	155	152	149
	4		245	242	238	235	232	228	225	222	218
	6		315	311	308	305	301	298	295	291	288
	8		384	381	378	374	371	368	364	361	358
	10		454	451	447	444	441	437	434	431	427
	12		524	520	517	514	510	507	504	500	497
	14		593	590	587	583	580	577	573	570	566

* CFM (Cubic Feet per Minute)

9" diameter EmpiCOP USECO-006 Tint 80°F

		Tint °F	80	80	80	80	80	80	80	80	
		Text °F	60	65	70	75	80	85	90	95	100
V MPH	2		174*	170	166	161	157	153	149	144	140
	4		263	259	254	250	246	242	237	233	229
	6		351	347	343	339	334	330	326	322	317
	8		440	436	432	427	423	419	415	410	406
	10		529	524	520	516	512	507	503	499	495
	12		617	613	609	604	600	596	592	587	583
	14		706	702	697	693	689	685	680	676	672

* CFM (Cubic Feet per Minute)

EmpiCOP USECO-006 Tint 90°F

		Tint °F	90	90	90	90	90	90	90	90	
		Text °F	60	65	70	75	80	85	90	95	100
V MPH	2		191*	186	182	178	174	169	165	161	157
	4		279	275	271	267	262	258	254	249	245
	6		368	364	359	355	351	347	342	338	334
	8		456	452	448	444	439	435	431	427	422
	10		545	541	537	532	528	524	520	515	511
	12		634	629	625	621	617	612	608	604	600
	14		722	718	714	710	705	701	697	692	688

* CFM (Cubic Feet per Minute)

EmpiCOP USECO-006 Tint 100°F

		Tint °F	100	100	100	100	100	100	100	100	
		Text °F	60	65	70	75	80	85	90	95	100
V MPH	2		207*	203	199	194	190	186	182	177	173
	4		296	291	287	283	279	274	270	266	262
	6		384	380	376	372	367	363	359	355	350
	8		473	469	464	460	456	452	447	443	439
	10		562	557	553	549	545	540	536	532	527
	12		650	646	633	637	633	629	625	620	616
	14		739	734	730	726	722	717	713	709	705

* CFM (Cubic Feet per Minute)

EmpiCOP USECO-006 Tint 110°F

		Tint °F	110	110	110	110	110	110	110	110	
		Text °F	60	65	70	75	80	85	90	95	100
V MPH	2		224*	219	215	211	207	202	198	194	190
	4		312	308	304	299	295	291	287	282	278
	6		401	397	392	388	384	379	375	371	367
	8		489	485	481	477	472	468	464	460	455
	10		578	574	569	565	561	557	552	548	544
	12		667	662	658	654	650	645	641	637	633
	14		755	751	747	742	738	734	730	725	721

* CFM (Cubic Feet per Minute)

10" diameter EmpiCOP USECO-007 Tint 80°F

	Tint °F	80	80	80	80	80	80	80	80	80
	Text °F	60	65	70	75	80	85	90	95	100
V MPH	2	212*	206	201	196	191	186	181	176	170
	4	319	314	309	304	299	293	288	283	278
	6	427	422	417	411	406	401	396	391	386
	8	534	529	524	519	514	509	503	498	493
	10	642	637	632	627	621	616	611	606	601
	12	750	744	739	734	729	724	719	713	708
	14	857	852	847	842	837	831	826	821	816

* CFM (Cubic Feet per Minute)

EmpiCop USECO-007 Tint 90°F

	Tint °F	90	90	90	90	90	90	90	90	90
	Text °F	60	65	70	75	80	85	90	95	100
V MPH	2	232*	226	221	216	211	206	201	195	190
	4	339	334	329	324	319	313	308	303	298
	6	447	442	436	431	426	421	416	411	405
	8	554	549	544	539	534	529	523	518	513
	10	662	657	652	646	641	636	631	626	621
	12	770	764	759	754	749	744	739	733	728
	14	877	872	867	862	856	851	846	841	836

* CFM (Cubic Feet per Minute)

EmpiCop USECO-007 Tint 100°F

	Tint °F	100	100	100	100	100	100	100	100	100
	Text °F	60	65	70	75	80	85	90	95	100
V MPH	2	252*	246	241	236	231	226	221	215	210
	4	359	354	349	344	339	333	328	323	318
	6	467	462	456	451	446	441	436	431	425
	8	574	569	564	559	554	549	543	538	533
	10	682	677	672	666	661	656	651	646	641
	12	790	784	779	774	769	764	759	753	748
	14	897	892	887	882	876	871	866	861	856

* CFM (Cubic Feet per Minute)

EmpiCop USECO-007 Tint 110°F

	Tint °F	110	110	110	110	110	110	110	110	110
	Text °F	60	65	70	75	80	85	90	95	100
V MPH	2	272*	266	261	256	251	246	241	235	230
	4	379	374	369	364	358	353	348	343	338
	6	487	482	476	471	466	461	456	451	445
	8	594	589	584	579	574	569	563	558	553
	10	702	697	692	686	681	676	671	666	661
	12	810	804	799	794	789	784	779	773	768
	14	917	912	907	902	896	891	886	881	876

* CFM (Cubic Feet per Minute)

12" diameter EmpiCop USECO-008 Tint 80°F

		Tint °F	80	80	80	80	80	80	80	80	
		Text °F	60	65	70	75	80	85	90	95	100
V MPH	2		357*	349	340	331	322	314	305	296	288
	4		539	530	521	513	504	495	486	478	469
	6		720	711	703	694	685	677	668	659	650
	8		902	893	884	875	867	858	849	841	832
	10		1083	1074	1066	1057	1048	1039	1031	1022	1013
	12		1264	1256	1247	1238	1230	1221	1212	1203	1195
	14		1446	1437	1428	1420	1411	1402	1394	1385	1376

* CFM (Cubic Feet per Minute)

EmpiCop USECO-008 Tint 90°F

		Tint °F	90	90	90	90	90	90	90	90	
		Text °F	60	65	70	75	80	85	90	95	100
V MPH	2		391*	382	374	365	356	347	339	330	321
	4		572	564	555	546	538	529	520	511	503
	6		754	745	736	728	719	710	702	693	648
	8		935	926	918	909	900	892	883	874	868
	10		1117	1108	1099	1090	1082	1073	1064	1056	1047
	12		1298	1289	1281	1272	1263	1254	1246	1237	1228
	14		1479	1471	1462	1453	1445	1436	1427	1418	1410

* CFM (Cubic Feet per Minute)

EmpiCop USECO-008 Tint 100°F

		Tint °F	100	100	100	100	100	100	100	100	
		Text °F	60	65	70	75	80	85	90	95	100
V MPH	2		425*	416	407	398	390	381	372	364	355
	4		606	597	589	580	571	562	554	545	536
	6		787	779	770	761	753	744	735	726	718
	8		969	960	951	943	934	925	917	908	899
	10		1150	1142	1133	1124	1115	1107	1098	1089	1081
	12		1332	1323	1314	1306	1297	1288	1279	1271	1262
	14		1513	1504	1496	1487	1478	1470	1461	1452	1443

* CFM (Cubic Feet per Minute)

EmpiCop USECO-008 Tint 110°F

		Tint °F	110	110	110	110	110	110	110	110	
		Text °F	60	65	70	75	80	85	90	95	100
V MPH	2		458*	450	441	432	423	415	406	397	389
	4		640	631	622	614	605	596	587	579	570
	6		821	812	804	795	786	778	769	760	751
	8		1003	994	985	976	968	959	950	942	933
	10		1184	1175	1167	1158	1148	1140	1132	1123	1114
	12		1365	1357	1348	1339	1331	1322	1313	1304	1296
	14		1547	1538	1529	1521	1512	1503	1495	1486	1477

* CFM (Cubic Feet per Minute)

14" diameter EmpiCOP USECO-009 Tint 80°F

		Tint °F	80	80	80	80	80	80	80	80	
		Text °F	60	65	70	75	80	85	90	95	100
V MPH	2		457*	446	435	424	413	401	390	379	368
	4		689	678	667	656	645	633	622	611	600
	6		921	910	899	888	877	866	854	843	832
	8		1153	1142	1131	1120	1109	1098	1086	1075	1064
	10		1385	1374	1363	1352	1341	1330	1318	1307	1296
	12		1617	1606	1595	1584	1827	1562	1551	1239	1528
	14		1849	1838	1827	1816	1805	1794	1783	1771	1760

* CFM (Cubic Feet per Minute)

EmpiCOP USECO-009 Tint 90°F

		Tint °F	90	90	90	90	90	90	90	90	
		Text °F	60	65	70	75	80	85	90	95	100
V MPH	2		500*	489	478	467	456	444	433	422	411
	4		732	721	710	699	688	677	665	654	643
	6		964	953	942	931	920	909	897	886	875
	8		1196	1185	1174	1163	1152	1141	1129	1118	1107
	10		1428	1417	1406	1395	1384	1373	1362	1350	1339
	12		1660	1649	1638	1627	1616	1605	1594	1582	1571
	14		1892	1881	1870	1859	1848	1837	1826	1814	1803

* CFM (Cubic Feet per Minute)

EmpiCOP USECO-009 Tint 100°F

		Tint °F	100	100	100	100	100	100	100	100	
		Text °F	60	65	70	75	80	85	90	95	100
V MPH	2		543*	532	521	510	499	488	476	465	454
	4		775	764	753	742	731	720	708	697	686
	6		1007	996	985	974	963	852	941	929	918
	8		1239	1228	1217	1206	1195	1184	1173	1161	1150
	10		1471	1460	1449	1438	1427	1416	1405	1393	1382
	12		1703	1692	1681	1670	1659	1648	1637	1626	1614
	14		1936	1924	1913	1902	1891	1880	1869	1858	1846

* CFM (Cubic Feet per Minute)

EmpiCOP USECO-009 Tint 110°F

		Tint °F	110	110	110	110	110	110	110	110	
		Text °F	60	65	70	75	80	85	90	95	100
V MPH	2		586*	575	564	553	542	531	519	508	497
	4		818	807	796	785	774	863	752	740	729
	6		1050	1039	1028	1017	1006	995	984	972	961
	8		1282	1271	1260	1249	1238	1227	1216	1204	1193
	10		1515	1503	1492	1481	1470	1459	1448	1437	1425
	12		1747	1735	1724	1713	1702	1691	1680	1669	1657
	14		1979	1967	1956	1945	1934	1923	1912	1901	1889

* CFM (Cubic Feet per Minute)

16" diameter EmpiCOP USECO-010 Tint 80°F

	Tint °F	80	80	80	80	80	80	80	80	80
	Text °F	60	65	70	75	80	85	90	95	100
V MPH	2	528*	515	502	489	476	764	451	438	425
	4	796	783	770	757	744	731	719	706	694
	6	1064	1051	1038	1025	1012	999	986	974	961
	8	1332	1319	1306	1293	1280	1267	1254	1242	1229
	10	1599	1587	1574	1561	1548	1535	1522	1509	1497
	12	1867	2122	1842	1829	1816	1803	1790	1777	1764
	14	2135	2122	2110	2097	2084	2071	2058	2045	2032

* CFM (Cubic Feet per Minute)

EmpiCOP USECO-010 Tint 90°F

	Tint °F	90	90	90	90	90	90	90	90	90
	Text °F	60	65	70	75	80	85	90	95	100
V MPH	2	578*	565	552	539	526	513	500	488	475
	4	845	833	820	807	794	781	768	755	743
	6	1113	1101	1088	1075	1062	1049	1036	1023	1010
	8	1381	1368	1356	1343	1330	1317	1304	1291	1278
	10	1649	1636	1623	1611	1598	1585	1572	1559	1546
	12	1917	1904	1891	1879	1866	1853	1840	1827	1814
	14	2185	2172	2159	2146	2134	2121	2108	2095	2082

* CFM (Cubic Feet per Minute)

EmpiCOP USECO-010 Tint 100°F

	Tint °F	100	100	100	100	100	100	100	100	100
	Text °F	60	65	70	75	80	85	90	95	100
V MPH	2	627*	614	602	589	576	563	550	537	524
	4	895	882	869	857	844	831	818	805	792
	6	1163	1150	1137	1125	1112	1099	1086	1073	1060
	8	1431	1418	1405	1392	1380	1367	1354	1341	1328
	10	1699	1686	1673	1660	1647	1635	1622	1609	1596
	12	1967	1954	1941	1928	1915	1903	1890	1877	1864
	14	2235	2222	2209	2196	2183	2170	2158	2145	2132

* CFM (Cubic Feet per Minute)

EmpiCOP USECO-010 Tint 110°F

	Tint °F	110	110	110	110	110	110	110	110	110
	Text °F	60	65	70	75	80	85	90	95	100
V MPH	2	677*	664	651	638	626	613	600	587	574
	4	942	932	919	906	893	881	868	855	842
	6	1213	1200	1187	1174	1161	1149	1136	1123	1110
	8	1481	1442	1455	1442	1429	1416	1404	1391	1378
	10	1749	1736	1723	1713	1697	1684	1671	1659	1646
	12	2017	2004	1991	1978	1965	1952	1939	1927	1914
	14	2284	2272	2259	2246	2233	2220	2207	2194	2182

* CFM (Cubic Feet per Minute)

18" diameter EmpiCOP USECO-011 Tint 80°F

	Tint °F	80	80	80	80	80	80	80	80	80
	Text °F	60	65	70	75	80	85	90	95	100
V MPH	2	657*	641	625	609	593	577	561	545	529
	4	990	974	958	942	926	910	894	878	862
	6	1323	1307	1291	1275	1259	1243	1227	1211	1195
	8	1657	1641	1625	1609	1593	1577	1561	1545	1529
	10	1990	1974	1958	1942	1926	1910	1894	1878	1862
	12	2323	2307	2291	2275	2259	2243	2227	2211	2195
	14	2657	2641	2625	2609	2593	2577	2561	2545	2529

* CFM (Cubic Feet per Minute)

EmpiCOP USECO-011 Tint 90°F

	Tint °F	90	90	90	90	90	90	90	90	90
	Text °F	60	65	70	75	80	85	90	95	100
V MPH	2	719*	703	687	671	655	639	623	607	591
	4	1052	1036	1020	1004	988	972	956	940	924
	6	1385	1369	1353	1337	1321	1305	1289	1273	1257
	8	1719	1703	1687	1671	1655	1639	1623	1607	1591
	10	2052	2036	2020	2004	1988	1972	1956	1940	1924
	12	2385	2369	2353	2337	2321	2305	2289	2273	2257
	14	2718	2702	2686	2670	2654	2638	2622	2606	2590

* CFM (Cubic Feet per Minute)

EmpiCOP USECO-011 Tint 100°F

	Tint °F	100	100	100	100	100	100	100	100	100
	Text °F	60	65	70	75	80	85	90	95	100
V MPH	2	781*	765	749	733	717	701	685	669	653
	4	1114	1098	1082	1066	1050	1034	1018	1002	986
	6	1447	1431	1415	1399	1383	1367	1351	1335	1319
	8	1780	1764	1748	1732	1716	1700	1684	1668	1652
	10	2114	2098	2082	2066	2050	2034	2018	2002	1986
	12	2447	2431	2415	2399	2383	2367	2351	2335	2319
	14	2780	2764	2748	2732	2716	2700	2684	2668	2652

* CFM (Cubic Feet per Minute)

EmpiCOP USECO-011 Tint 110°F

	Tint °F	110	110	110	110	110	110	110	110	110
	Text °F	60	65	70	75	80	85	90	95	100
V MPH	2	842*	826	810	794	778	762	746	730	714
	4	1176	1160	1144	1128	1112	1096	1080	1064	1048
	6	1509	1493	1477	1461	1445	1429	1413	1397	1381
	8	1842	1826	1810	1794	1778	1762	1746	1730	1714
	10	2176	2160	2144	2128	2112	2096	2080	2064	2048
	12	2509	2493	2477	2461	2445	2429	2413	2397	2381
	14	2842	2826	2810	2794	2778	2762	2746	2730	2714

* CFM (Cubic Feet per Minute)

20" diameter EmpiCOP USECO-012 Tint 80°F

	Tint °F	80	80	80	80	80	80	80	80	80
	Text °F	60	65	70	75	80	85	90	95	100
V MPH	2	790*	771	751	732	713	694	674	655	636
	4	1191	1171	1152	1133	1075	1095	1075	1056	1037
	6	1592	1572	1553	1534	1515	1495	1476	2457	1438
	8	1992	1973	1954	1935	1915	1896	1877	1858	1838
	10	2393	2374	2355	2335	2316	2297	2278	2258	2239
	12	2794	2775	2755	1736	2717	2698	2679	2659	2640
	14	3195	3176	3156	3176	3156	3099	3079	3060	3041

* CFM (Cubic Feet per Minute)

EmpiCop USECO-012 Tint 90°F

	Tint °F	90	90	90	90	90	90	90	90	90
	Text °F	60	65	70	75	80	85	90	95	100
V MPH	2	864*	845	826	807	787	768	749	730	710
	4	1265	1246	1227	1207	1188	1169	1150	1130	1111
	6	1666	1647	1627	1608	1589	1570	1550	1531	1512
	8	2067	2047	2028	2009	1990	1971	1951	1932	1913
	10	2468	2448	2429	2410	2391	2371	2352	2333	2314
	12	2868	2849	2830	2811	2791	2772	2753	2734	2714
	14	3269	3250	3231	3211	3192	3173	3154	3134	3115

* CFM (Cubic Feet per Minute)

EmpiCop USECO-012 Tint 100°F

	Tint °F	100	100	100	100	100	100	100	100	100
	Text °F	60	65	70	75	80	85	90	95	100
V MPH	2	939*	919	900	881	862	843	823	804	785
	4	1340	1320	1301	1282	1263	1243	1224	1205	1186
	6	1740	1721	1702	1683	1663	1644	1625	1606	1586
	8	2141	2122	2103	2083	2465	2045	2026	2006	1987
	10	2542	2523	2503	2484	2465	2446	2427	2407	2388
	12	2943	2924	2904	2885	2866	2847	2827	2808	2789
	14	3344	3324	3305	3286	3267	3247	3228	3209	3190

* CFM (Cubic Feet per Minute)

EmpiCop USECO-012 Tint 110°F

	Tint °F	110	110	110	110	110	110	110	110	110
	Text °F	60	65	70	75	80	85	90	95	100
V MPH	2	1013*	994	975	955	936	917	898	878	859
	4	1414	1395	1375	1356	1337	1318	1298	1279	1260
	6	1815	1795	1776	1757	1738	1719	1699	1680	1661
	8	2216	2196	2177	2158	2139	2119	2100	2081	2062
	10	2616	2597	2578	2559	2539	2520	2501	2482	2462
	12	3017	2998	2979	2959	2940	2921	2902	2882	2863
	14	3418	3399	3379	3360	3341	3322	3303	3283	3264

* CFM (Cubic Feet per Minute)

24" diameter EmpiCOP USECO-013 Tint 80°F

		Tint °F	80	80	80	80	80	80	80	80	
		Text °F	60	65	70	75	80	85	90	95	100
V MPH	2		1144*	1116	1088	1060	1032	1004	976	949	921
	4		1724	1696	1668	1640	1612	1584	1557	1529	1501
	6		2304	2276	2248	2220	2192	2165	2137	2109	2081
	8		2884	2856	2828	2800	2772	2745	2717	2689	2661
	10		3464	3436	3408	3380	3353	3325	3297	3269	3241
	12		4044	4016	3988	3961	3933	4485	3877	3849	3821
	14		4624	4596	4569	4541	4513	4485	4457	4429	4401

* CFM (Cubic Feet per Minute)

EmpiCOP USECO-013 Tint 90°F

		Tint °F	90	90	90	90	90	90	90	90	
		Text °F	60	65	70	75	80	85	90	95	100
V MPH	2		1251*	1223	1196	1168	1140	1112	1084	1056	1028
	4		1831	1803	1776	1748	1720	1692	1664	1636	1609
	6		2411	2384	2356	2328	2300	2272	2244	2217	2189
	8		2992	2964	2936	2908	2880	2852	2824	2797	2769
	10		3572	3544	3516	3488	3460	3432	3405	3377	3349
	12		4152	4124	4096	4068	4040	4013	3985	3957	3929
	14		4732	4704	4676	4648	4621	4593	4565	4537	4509

* CFM (Cubic Feet per Minute)

EmpiCOP USECO-013 Tint 100°F

		Tint °F	100	100	100	100	100	100	100	100	
		Text °F	60	65	70	75	80	85	90	95	100
V MPH	2		1359*	1331	1303	1275	1247	1220	1192	1164	1136
	4		1939	1911	1883	1855	1828	1800	1772	1744	1716
	6		2519	2491	2463	2436	2408	2380	2352	2324	2296
	8		3099	3071	3044	3016	2988	2960	2932	2904	2876
	10		3679	3652	3624	3596	3568	3540	3512	3484	3457
	12		4259	4232	4204	4176	4092	4120	4092	4065	4037
	14		4840	4812	4784	4812	4728	4700	4673	4645	4617

* CFM (Cubic Feet per Minute)

EmpiCOP USECO-013 Tint 110°F

		Tint °F	110	110	110	110	110	110	110	110	
		Text °F	60	65	70	75	80	85	90	95	100
V MPH	2		1467*	1439	1411	1383	1355	1327	1299	1272	1244
	4		2047	2019	1991	1963	1935	1907	1880	1852	1824
	6		2627	2599	2571	2543	2515	2488	2460	2432	2404
	8		3207	3179	3151	3123	3096	3068	3040	3012	2984
	10		3787	3759	3731	3703	3676	3648	3620	3592	3564
	12		4367	4339	4311	4284	4256	4228	4200	4172	4144
	14		4947	4919	4892	4864	4836	4808	4780	4752	4724

* CFM (Cubic Feet per Minute)