

**General Characteristics of CA Series Comfort Aide Direct-Drive Whole House Fan**

Our CA is fabricated from heavy steel with a baked powder coat finish; these fans are durable and whisper quiet. Two-speed direct drive motor, Pull Chain operation or optional two speed wall switch. Three-wing blade pitched at maximum angle to permit good air flow. These units are capable of cooling your home to the outside temperature 5-10 times faster than central air conditioning and at less than 1/10<sup>th</sup> of the cost. Rubber mounted motor mounts for quieter operation. Heavy gauge steel welded construction. Easy installation. No joists to cut with Standard shutter included with fan. Optional two-speed wall switch



**Product Applications of CA Series Comfort Aide Direct-Drive Whole House Fan**

Recommended for Commercial Buildings. Useful to exhaust extra heat, odors, and for general ventilation purposes.

**Warranty of CA Series Comfort Aide Direct-Drive Whole House Fan**

Includes Manufacturer's Limited Warranty: 1 Year

**Specific Characteristics of CA Series Comfort Aide Direct-Drive Whole House Fan**

Item#	Manufacturing #	Blade Dia. (In.)	CFM		Volts V	Amps A	RPM		HP	Speed	Shutter Option	Weight and Dimensions with Packaging	
			HI	LO			HI	LO				Lbs.	L,W,H In.
			USCFA-001	CA2421 S			24	4,000					
USCFA-002	CA3021 S	30	5,900	4,700	115	2.0	815	650	1/4	2	Not Included	64	36,11,36

**Dimensions (In.) of CA Series Comfort Aide Direct-Drive Whole House Fan**

Series	Length A	Width B	Height C
USCFA-001	30"	09"	30"
USCFA-002	34"	09"	34"



**Dimensions Diagram of CE Series Belt-Drive Exhaust Fan**

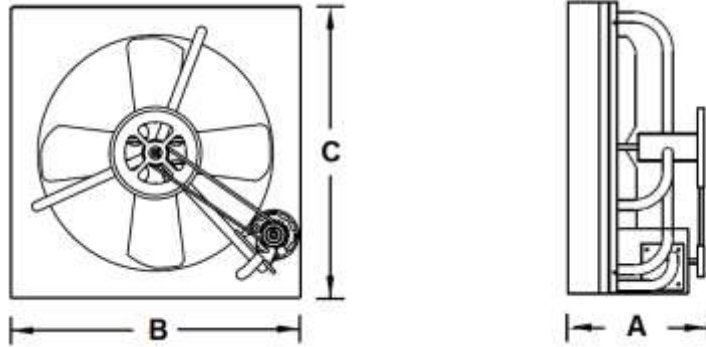

<b>Cooling Information for CE Series Belt-Drive Exhaust Fan</b>				
<b>Item #</b>	<b>Manufacturer #</b>	<b>Size</b>	<b>Square Footage Cooled</b>	<b>Min. Free Exhaust Area Required</b>
USCFA-001	CA2421 S	24	600-800	8 Sq Ft.
USCFA-002	CA3021 S	30	800-1000	10 Sq. Ft.