



General Characteristics of CE Series Belt-Drive Exhaust Fan

The CE Series belt drive exhaust fan is a commercial exhaust fan. For Commercial, indoor and outdoor use. Also used for ventilation and exhaust. The motor is available in two options 120V 1 Phase or 230/460V 3 Phase. It has a permanently lubricated bearing blade drive shaft, and a drip proof totally enclosed motor. The drive shaft has permanently lubricated bearings for longer life. Comes with Aluminum Blades. The venturi plate is finished with a powder coated paint. Specifics: 1725 RPM, Motor frame size 56 and 5/8" shaft. Is made in the U.S.A.

Product Applications of CE Series Belt-Drive Exhaust Fan

Recommended for Commercial Buildings. Useful to exhaust extra heat, odors, and for general ventilation purposes.

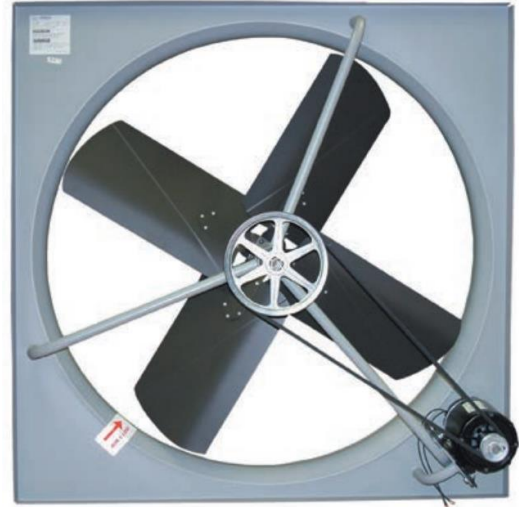

Warranty of CE Series Belt-Drive Exhaust Fan

Includes Manufacturer's Limited Warranty: 1 Year

Specific Characteristics of CE Series Belt-Drive Exhaust Fan

Item#	Manufacturing #	Blade Dia. (In.)	CFM	Volts V	Amperes A	Phases Ph	HP	Shutter Options	Weight and Dimensions with Packaging	
									Lbs.	L,W,H In.
USBXT-001	CE-24B	24	3270	115	5	1	1/3	-	52	19,30,31
USBXT-002	CE-24B + CES-24	24	3270	115	5	1	1/3	Shutter	63	19,30,31
USBXT-003	CE-24B-3	24	3270	230/460	6	3	1/3	-	52	19,30,31
USBXT-004	CE-24B-3 + CES-24	24	3270	230/460	6	3	1/3	Shutter	63	19,30,31
USBXT-005	CE-30B	30	7730	115	8	1	1/3	-	60	19,36,37
USBXT-006	CE-30B + CES-30	30	7730	115	8	1	1/3	Shutter	77	19,36,37
USBXT-007	CE-30B-3	30	9870	230/460	1.9/9	1	1/3	-	60	19,36,37
USBXT-008	CE-30B-3 + CES-30	30	9870	230/460	1.9/9	1	1/3	Shutter	77	19,36,37
USBXT-009	CE-36B	36	9870	115	8	3	1/2	-	67	19,42,43
USBXT-010	CE-36B + CES-36	36	9870	115	8	3	1/2	Shutter	84	19,42,43
USBXT-011	CE-36B-3	36	9870	230/460	2.3/1.1	1	1/2	-	67	19,42,43
USBXT-012	CE-36B-3 + CES-36	36	9870	230/460	2.3/1.1	1	1/2	Shutter	84	19,42,43
USBXT-013	CE-42B	42	11300	115	11	1	3/4	-	77	19,50,50
USBXT-014	CE-42B + CES-42	42	11300	115	11	1	3/4	Shutter	100	19,50,50
USBXT-015	CE-42B-3	42	11300	230/460	3.3/1.5	3	3/4	-	77	19,50,50
USBXT-016	CE-42B-3 + CES-42	48	11300	230/460	3.3/1.5	3	3/4	Shutter	100	19,50,50
USBXT-017	CE-48B	48	16500	115	15	1	1	-	100	19,56,56
USBXT-018	CE-48B + CES-48	48	16500	115	15	1	1	Shutter	128	19,56,56
USBXT-019	CE-48B-3	48	16500	230/460	3.8/1.9	1	1	-	100	19,56,56
USBXT-020	CE-48B-3 + CES-48	48	16500	230/460	3.8/1.9	1	1	Shutter	128	19,56,56



Dimensions (In.) of CE Series Belt-Drive Exhaust Fan

Series	Length A	Width B	Height C
USBXT-001 to 004	17.75"	28"	29.5"
USBXT-005 to 008	17.75"	34"	35.5"
USBXT-009 to 012	17.75"	40"	41.5"
USBXT-013 to 016	17.75"	48"	48"
USBXT-017 to 020	17.75"	54"	54"

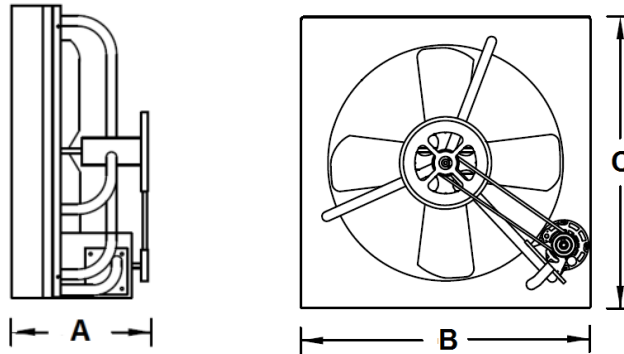

Short Description of CE Series Belt-Drive Exhaust Fan

Item #	Manufacturing #	Short Description 70 Characters Maximum
USBXT-001	CE-24B	24", 3270CFM, 115V, 5A, 1PH, 1/3HP, No Shutter.

SEO Table of CE Series Belt-Drive Exhaust Fan

Title
TPI CE Series Belt-Drive Exhaust Fan.
Meta Description
TPI CE Series Belt-Drive Exhaust Fan for Commercial use, TPI CE Series Belt-Drive Exhaust Fan for Indoor Use, TPI CE Series Belt-Drive Exhaust Fan for Outdoor Use, TPI CE Series Belt-Drive Exhaust Fan Exhaust Use, TPI CE Series Belt-Drive Exhaust Fan Ventilation Use.
Meta Key Words
TPI CE Series Belt-Drive Exhaust Fan for Commercial use, TPI CE Series Belt-Drive Exhaust Fan for Indoor Use, TPI CE Series Belt-Drive Exhaust Fan for Outdoor Use, TPI CE Series Belt-Drive Exhaust Fan Exhaust Use, TPI CE Series Belt-Drive Exhaust Fan Ventilation Use.
Meta URL (file name)
Tpi-ce-series-belt-drive-exhaust-fan-us-english.htm

Product Line Description of CE Series Belt-Drive Exhaust Fan

 Type: TPI CE Series Belt-Drive Exhaust Fan

 Drive Type: Belt Drive

 Motor Type: Totally Enclosed

 Manufacturer: TPI

 Model Series: CE

 Voltage: 115 or 230/460V

 Horse Power: 1/3, 1/2, 3/4 or 1Hp

 Diameters: 24", 30", 36", 42" & 48"

 Air Flow: 3270 to 16500CFM

 Weather Rating: Outdoor/Indoor

 Shutter Options: With or Without Shutter

 Ships By: Free LTL Freight

