



General Characteristics of 2600 Series Anemostat Diffuser Down Flow Unit Heater

The 2600 Series Anemostat Diffuser is a down flow unit heater; constructed with 16 gauge steel cabinet with epoxy powder coated finish and control compartment with a hinged and latched access door.

OSHA guards standard with all models.

For industrial and commercial use.

For indoor use where heat needs to be forced down from ceiling.

The heating element is corrosion resistant with steel sheath and steel spiral fins.

Overheat protection: All units come equipped with manual reset limit controls to de-energize the heater should an over-temperature situation occur.

The motor is totally enclosed, 1 speed, 1 phase permanently lubricated, thermally protected motors with unit bearings on 3KW to 20KW models.

Totally enclosed, 2 speed, 1 phase permanently lubricated, thermally protected motors with sleeve bearings on 24KW to 50KW models.

Axial flow fan blade - 1570 RPM max.

All Models equipped with Fan Purge which allows Fan to operate after elements are de-energized to purge residual heat.

Temperature controls: 208V, 240V, 277V, and 480V units have built in 24 volt transformer for low voltage remote thermostat application.

600V units have in-built 240V control on 5-20 Kw models; 25-50Kw models have 24V control.

25Kw models may operate as 2 stage heaters if 2 stage remote thermostats are used.

Disconnect switch: all models equipped with in-built disconnect except F3F2640, F3F2650 and H3H2650.

Installation: unit can be mounted using optional mounting bracket or field constructed angle iron bracket

Not recommended for mounting with threaded rod or chain

The 2600 Series Anemostat Diffuser shown with standard wire guard.

Diffusers are field installed

Minimum mounting height is 6 feet.

This product is ETL-CETL listed.

Made in the U.S.A.



Product Applications of 2600 Series Anemostat Diffuser Down Flow Unit Heater

Industrial and Commercial use where heat needs to be forced down from ceiling. Used to heat factories, shops, bakeries, gymnasiums, warehouses, offices, etc.

For indoor use.

Warranties and Guaranties of 2600 Series Anemostat Diffuser Down Flow Unit Heater

Manufacturer's Limited Warranty: 1 year.



Specific Characteristics of 2600 Series Anemostat Diffuser Down Flow Unit Heater

Item #	Manufacturing #	Kilowatts Kw	BTU's	Volts V	Phases Ph	Amperes A	Control Volts	Temp Rise (°F)	CFM	Bracket Options	Weight and Dimensions with Packaging	
											Lbs.	L,W,H In.
USADH-001	F1F2605CA1 + D1603	5	17065	208	1	24.03	24	34	490	-	80	22,22,24
USADH-002	F1F2605CA1 + D1603 + A1600	5	17065	208	1	24.03	24	34	490	Bracket	87	22,22,24
USADH-003	H1H2605CA1 + D1603	5	17065	240	1	20.83	24	34	490	-	80	22,22,24
USADH-004	H1H2605CA1 + D1603 + A1600	5	17065	240	1	20.83	24	34	490	Bracket	87	22,22,24
USADH-005	G1G2605CA1 + D1603	5	17065	277	1	18.05	24	34	490	-	80	22,22,24
USADH-006	G1G2605CA1 + D1603 + A1600	5	17065	277	1	18.05	24	34	490	Bracket	87	22,22,24
USADH-007	F3F2605CA1 + D1603	5	17065	208	3	13.89	24	34	490	-	80	22,22,24
USADH-008	F3F2605CA1 + D1603 + A1600	5	17065	208	3	13.89	24	34	490	Bracket	87	22,22,24
USADH-009	H3H2605CA1 + D1603	5	17065	240	3	12.04	24	34	490	-	80	22,22,24
USADH-010	H3H2605CA1 + D1603 + A1600	5	17065	240	3	12.04	24	34	490	Bracket	87	22,22,24
USADH-011	P3P2605CA1 + D1603	5	17065	480	3	6.02	24	34	490	-	80	22,22,24
USADH-012	P3P2605CA1 + D1603 + A1600	5	17065	480	3	6.02	24	34	490	Bracket	87	22,22,24
USADH-013	F1F2607CA1 + D1603	7.5	25598	208	1	36.05	24	45	560	-	80	22,22,24
USADH-014	F1F2607CA1 + D1603 + A1600	7.5	25598	208	1	36.05	24	45	560	Bracket	87	22,22,24
USADH-015	H1H2607CA1 + D1603	7.5	25598	240	1	31.25	24	45	560	-	80	22,22,24
USADH-016	H1H2607CA1 + D1603 + A1600	7.5	25598	240	1	31.25	24	45	560	Bracket	87	22,22,24
USADH-017	G1G2607CA1 + D1603	7.5	25598	277	1	27.07	24	45	560	-	80	22,22,24
USADH-018	G1G2607CA1 + D1603 + A1600	7.5	25598	277	1	27.07	24	45	560	Bracket	87	22,22,24
USADH-019	F3F2607CA1 + D1603	7.5	25598	208	3	20.84	24	45	560	-	80	22,22,24
USADH-020	F3F2607CA1 + D1603 + A1600	7.5	25598	208	3	20.84	24	45	560	Bracket	87	22,22,24
USADH-021	H3H2607CA1 + D1603	7.5	25598	240	3	18.06	24	45	560	-	80	22,22,24
USADH-022	H3H2607CA1 + D1603 + A1600	7.5	25598	240	3	18.06	24	45	560	Bracket	87	22,22,24
USADH-023	P3P2607CA1 + D1603	7.5	25598	480	3	9.03	24	45	560	-	80	22,22,24
USADH-024	P3P2607CA1 + D1603 + A1600	7.5	25598	480	3	9.03	24	45	560	Bracket	87	22,22,24
USADH-025	F1F2610CA1 + D1603	10	34130	208	1	48.07	24	26	1200	-	80	22,22,24
USADH-026	F1F2610CA1 + D1603 + A1600	10	34130	208	1	48.07	24	26	1200	Bracket	87	22,22,24
USADH-027	H1H2610CA1 + D1603	10	34130	240	1	41.66	24	26	1200	-	80	22,22,24
USADH-028	H1H2610CA1 + D1603 + A1600	10	34130	240	1	41.66	24	26	1200	Bracket	87	22,22,24
USADH-029	G1G2610CA1 + D1603	10	34130	277	1	36.1	24	26	1200	-	80	22,22,24
USADH-030	G1G2610CA1 + D1603 + A1600	10	34130	277	1	36.1	24	26	1200	Bracket	87	22,22,24
USADH-031	F3F2610CA1 + D1603	10	34130	208	3	27.79	24	26	1200	-	80	22,22,24
USADH-032	F3F2610CA1 + D1603 + A1600	10	34130	208	3	27.79	24	26	1200	Bracket	87	22,22,24
USADH-033	H3H2610CA1 + D1603	10	34130	240	3	24.08	24	26	1200	-	80	22,22,24
USADH-034	H3H2610CA1 + D1603 + A1600	10	34130	240	3	24.08	24	26	1200	Bracket	87	22,22,24
USADH-035	P3P2610CA1 + D1603	10	34130	480	3	12.04	24	26	1200	-	80	22,22,24
USADH-036	P3P2610CA1 + D1603 + A1600	10	34130	480	3	12.04	24	26	1200	Bracket	87	22,22,24
USADH-037	F3F2615CA1 + D1603	15	51195	208	3	41.68	24	39	1200	-	80	22,22,24
USADH-038	F3F2615CA1 + D1603 + A1600	15	51195	208	3	41.63	24	39	1200	Bracket	87	22,22,24
USADH-039	HEH2615CA1 + D1603	15	51195	240	3	36.12	24	39	1200	-	80	22,22,24
USADH-040	HEH2615CA1 + D1603 + A1600	15	51195	240	3	36.12	24	39	1200	Bracket	87	22,22,24
USADH-041	P3P2615CA1 + D1603	15	51195	480	3	18.06	24	39	1200	-	80	22,22,24
USADH-042	P3P2615CA1 + D1603 + A1600	15	51195	480	3	18.06	24	39	1200	Bracket	87	22,22,24
USADH-043	H3H2620CA1 + D1603	19.4	68260	240	3	18.16	24	52	1200	-	80	22,22,24
USADH-044	H3H2620CA1 + D1603 + A1600	19.4	68260	240	3	48.16	24	52	1200	Bracket	87	22,22,24



Item #	Manufacturing #	Kilowatts Kw	BTU's	Volts V	Phases Ph	Amperes A	Control Volts	Temp Rise (°F)	CFM	Bracket Options	Weight and Dimensions with Packaging	
											Lbs.	L,W,H In.
USADH-045	P3P2620CA1 + D1603	20	68260	480	3	24.08	24	52	1200	-	80	22,22,24
USADH-046	P3P2620CA1 + D1603 + A1600	20	68260	480	3	24.08	24	52	1200	Bracket	87	22,22,24
USADH-047	F3F2625CA1 + D1613	25	85325	208	3	69.48	24	24	3300	-	180	29,29,30
USADH-048	F3F2625CA1 + D1613 + A1600	25	85325	208	3	69.48	24	24	3300	Bracket	187	29,29,30
USADH-049	H3H2625CA1 + D1613	25	85325	240	3	60.21	24	24	3300	-	180	29,29,30
USADH-050	H3H2625CA1 + D1613 + A1600	25	85325	240	3	60.21	24	24	3300	Bracket	187	29,29,30
USADH-051	P3P2625CA1 + D1613	25	85325	480	3	30.1	24	24	3300	-	180	29,29,30
USADH-052	P3P2625CA1 + D1613 + A1600	25	85325	480	3	30.1	24	24	3300	Bracket	187	29,29,30
USADH-053	F3F2630CA1 + D1613	30	102390	208	3	83.37	24	29	3300	-	180	29,29,30
USADH-054	F3F2630CA1 + D1613 + A1600	30	102390	208	3	83.37	24	29	3300	Bracket	187	29,29,30
USADH-055	H3H2630CA1 + D1613	30	102390	240	3	72.25	24	29	3300	-	180	29,29,30
USADH-056	H3H2630CA1 + D1613 + A1600	30	102390	240	3	72.25	24	29	3300	Bracket	187	29,29,30
USADH-057	P3P2630CA1 + D1613	30	102390	480	3	36.12	24	29	3300	-	180	29,29,30
USADH-058	P3P2630CA1 + D1613 + A1600	30	102390	480	3	36.12	24	29	3300	Bracket	187	29,29,30
USADH-059	F3F2640CA1 + D1613	40	136520	208	3	111.17	24	38	3300	-	180	29,29,30
USADH-060	F3F2640CA1 + D1613 + A1600	40	136520	208	3	111.17	24	38	3300	Bracket	187	29,29,30
USADH-061	H3H2640CA1 + D1613	40	136520	240	3	96.33	24	38	3300	-	180	29,29,30
USADH-062	H3H2640CA1 + D1613 + A1600	40	136520	240	3	96.33	24	38	3300	Bracket	187	29,29,30
USADH-063	P3P2640CA1 + D1613	40	136520	480	3	48.16	24	38	3300	-	180	29,29,30
USADH-064	P3P2640CA1 + D1613 + A1600	40	136520	480	3	48.16	24	38	3300	Bracket	187	29,29,30
USADH-065	F3F2650CA1 + D1613	50	170650	208	3	138.96	24	48	3300	-	180	29,29,30
USADH-066	F3F2650CA1 + D1613 + A1600	50	170650	208	3	138.96	24	48	3300	Bracket	187	29,29,30
USADH-067	H3H2650CA1 + D1613	50	170650	240	3	120.42	24	48	3300	-	180	29,29,30
USADH-068	H3H2650CA1 + D1613 + A1600	50	170650	240	3	120.42	24	48	3300	Bracket	187	29,29,30
USADH-069	P3P2650CA1 + D1613	50	170650	480	3	60.12	24	48	3300	-	180	29,29,30
USADH-070	P3P2650CA1 + D1613 + A1600	50	170650	480	3	60.12	24	48	3300	Bracket	187	29,29,30

Dimensions (In.) of 2600 Series Anemostat Diffuser Down Flow Unit Heater

Series	Length A	Width B	Height C
USADH-001 to 046	20 ½"	20 ½"	15"
USADH-047 to 070	27"	27"	21 ½"

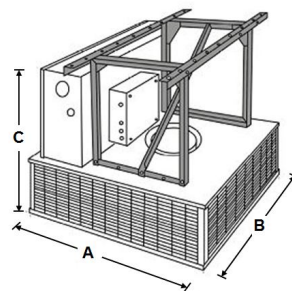
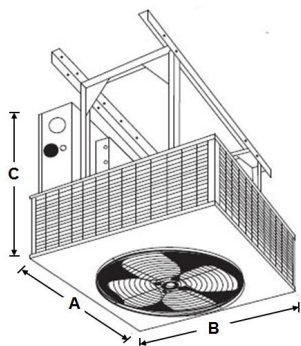

Mounting Bracket



Louver/Diffuser Dimensions of 2600 Series Anemostat Diffuser Down Flow Unit Heater

Series	Manufacturing #	Kilowatts Kw	Length A	Width B	Height C
USADH-001 to 046	D1603	5-20	19 1/4"	19 1/4"	7"
USADH-047 to 070	D1613	25-50	29 3/4"	29 3/4"	9 3/4"

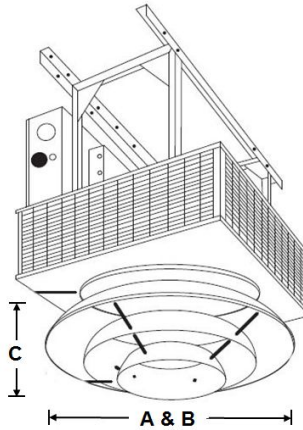

Mounting Height of 2600 Series Anemostat Diffuser Down Flow Unit Heater

Series	Max Mounting Height	Air Spread D' (Ft)
USADH-001 to 012	9	25
USADH-013 to 024	9	25
USADH-025 to 036	20	38
USADH-037 to 042	18	40
USADH-043 to 046	16	42
USADH-047 to 052	30	60
USADH-053 to 058	28	64
USADH-059 to 064	26	67
USADH-065 to 070	24	70

*Minimum mounting height is 6ft.

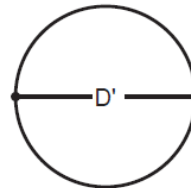

Short Description of 2600 Series Anemostat Diffuser Down Flow Unit Heater

Item #	Manufacturing #	Short Description 70 Characters Maximum
USADH-001	F1F2605CA1 + D1603	5Kw, 17065BTU's, 208V, 1Ph, 24.03A, Control 24V, Temp. Rise 34°F, CFM 490.



SEO Table of 2600 Series Anemostat Diffuser Down Flow Unit Heater

Title
TPI 2600 Series Anemostat Diffuser Down Flow Unit Heater.
Meta Description
TPI 2600 Series Anemostat Diffuser Down Flow Unit Heater for Industrial Use, TPI 2600 Series Anemostat Diffuser Down Flow Unit Heater for Commercial Use, TPI 2600 Series Anemostat Diffuser Down Flow Unit Heater for Indoor Use, TPI 2600 Series Anemostat Diffuser Down Flow Unit Heater for Heating Use.
Meta Key Words
TPI 2600 Series Anemostat Diffuser Down Flow Unit Heater for Industrial Use, TPI 2600 Series Anemostat Diffuser Down Flow Unit Heater for Commercial Use, TPI 2600 Series Anemostat Diffuser Down Flow Unit Heater for Indoor Use, TPI 2600 Series Anemostat Diffuser Down Flow Unit Heater for Heating Use.
Meta URL (file name)
Tpi-2600-series-anemostat-diffuser-down-flow-unit-heater-us-english.htm

Product Line Description of 2600 Series Anemostat Diffuser Down Flow Unit Heater

```

<FONT Size=1>
<b>Product Description:</b> TPI 2600 Series Anemostat Diffuser Down Flow Unit Heater<br>
<b>Weather Rating:</b> Indoor<br>
<b>Kilowatts:</b> 5 to 50Kw<br>
<b>BTU's:</b> 17065 to 170650<br>
<b>Voltage:</b> 208, 240, 277 & 480V<br>
<b>Phases:</b> 1 or 3Ph<br>
<b>Amperes:</b> 6.02 to 138.96A<br>
<b>Control Volts:</b> 24V<br>
<b>Temperature Rise (°F):</b> 24 to 52°F<br>
<b>CFM:</b> 490, 560, 1200 & 3300<br>
<b>Product Type:</b> TPI 2600 Series Anemostat Diffuser Down Flow Unit Heater<br>
<b>Usual Delivery Time or Lead Time:</b> 1 to 2 weeks<br>
<b>Shipping Type:</b> Fedex, UPS Package, LTL Freight<br>
</FONT>
    
```