

MegaTon

Características Generales de los Extractores Atmosféricos Gravitatorios + Eólicos, MegaTon

Los Extractores Atmosféricos Gravitatorios + Eólicos, MegaTon VentDepot, son equipos industriales de alta duración y tienen una capacidad de extracción altísima, ya que cuentan con 15 turbinas muy efectivas al viento, fabricadas en 100% Aluminio.

Incluyen base de extracción, cuello y turbina.

Bases disponibles en Lámina Galvanizada, Lámina Pintro y Aluminio. Ideales para instalarse en cumbrera a un agua altamente recomendado, techo plano y dos aguas.

Estos equipos ahorran energía eléctrica y están libres de mantenimiento.

Diseñado con las normas internacionales y aprobado por la I.V.S. (Industrial Ventilation Society).

Aplicaciones de los Extractores Atmosféricos Gravitatorios + Eólicos, MegaTon

Los Extractores Atmosféricos Gravitatorios + Eólicos MegaTon pueden extraer: Calor, vapor, humo, olores solventes y gases.

Para uso en: Naves industriales talleres, almacenes y/o lugares con alta salinidad o humedad, fabricas, ventilación general en bodegas de grandes dimensiones, entre otros.

Garantía de los Extractores Atmosféricos Gravitatorios + Eólicos, MegaTon

Los Extractores Atmosféricos Gravitatorios + Eólicos MegaTon, tienen una garantía de:

Base de Aluminio: 30 años.

Base de Lámina Pintro: 5 años.

Base de Lámina Galvanizada: 3 años.

Sujeto a las cláusulas de garantía de VentDepot.



Características Técnicas Específicas de los Extractores Atmosféricos Gravitatorios + Eólicos, MegaTon

Clave	Material de la base	Garganta		Caudal		Tipo de Techo	Calibre	Turbinas	Peso kg	Dimensiones con envoltura de plástico cm
		mm	in	m3/hr	CFM					
MXMAO-001	Galvanizado	914x2998	36x118	67500	39705	A 2 aguas y/o cumbrera	22	15	117	315x55x95
MXMAO-002	Galvanizado	914x2998	36x118	67500	39705	A 1 agua y/o perpendicular a cumbrera	22	15	117	315x55x95
MXMAO-003	Pintro	914x2998	36x118	67500	39705	A 2 aguas y/o cumbrera	22	15	117	315x55x95
MXMAO-004	Pintro	914x2998	36x118	67500	39705	A 1 agua y/o perpendicular a cumbrera	22	15	117	315x55x95
MXMAO-005	Aluminio	914x2998	36x118	67500	39705	A 2 aguas y/o cumbrera	22	15	72	315x55x95
MXMAO-006	Aluminio	914x2998	36x118	67500	39705	A 1 agua y/o perpendicular a cumbrera	22	15	72	315x55x95

Dimensiones de los Extractores Atmosféricos Gravitatorios + Eólicos, MegaTon

Vista Lateral

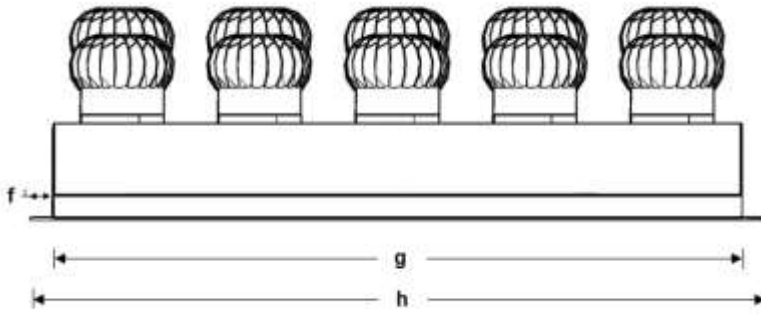

Vista Frontal

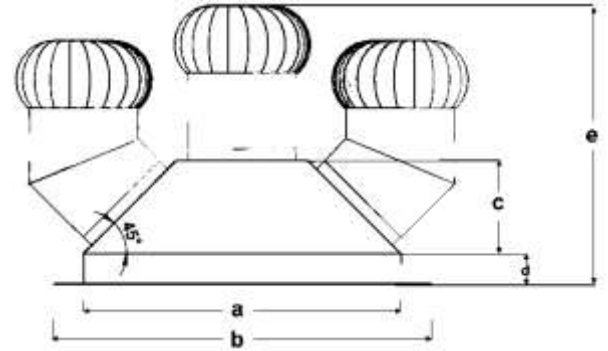

Vista Superior

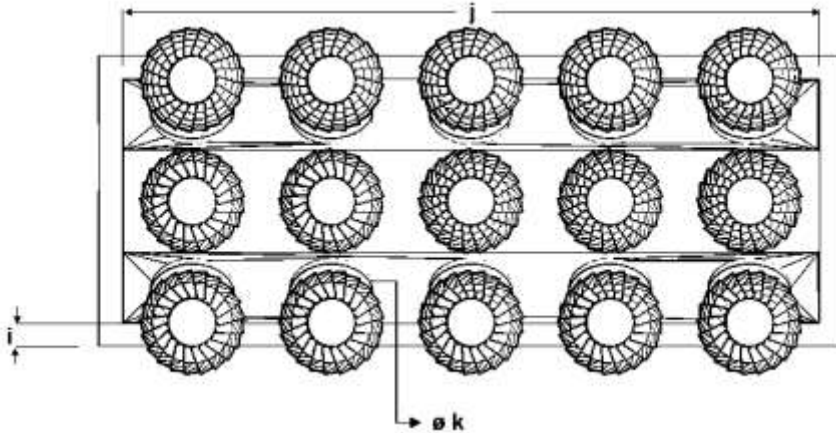

Dimensiones (mm)											
Clave	a	b	c	d	e	f	g	h	i	j	k
MXMAO-001	914	1016	250	100	934	100	2998	3098	102	2794	353
MXMAO-002	914	1016	250	100	934	100	2998	3098	102	2794	353
MXMAO-003	914	1016	250	100	934	100	2998	3098	102	2794	353
MXMAO-004	914	1016	250	100	934	100	2998	3098	102	2794	353
MXMAO-005	914	1016	250	100	934	100	2998	3098	102	2794	353
MXMAO-006	914	1016	250	100	934	100	2998	3098	102	2794	353

Fórmula para cálculo de Extracción de un MegaTon

De las fórmulas siguientes elegir la fórmula del MegaTon correspondiente.

Capacidad de Extracción para modelo **MXMAO-001** al **MXMAO-006**

$$\text{Extracción}^* \text{MXMAO-001} = (0.818 + [0.0303 \times A]) \times (121.5 + [103.4 \times V] + [11.6 \times G] + [5.6 \times T]) \times 18.9$$

A = Altura de montaje del MegaTon sobre el piso, en metros.

V = Velocidad del viento media anual, en km/hr.

G = Gradiente Térmico medio anual, en °C, (Temp. Interior. - Temp. Exterior.)

T = Temperatura Regional media anual, en °C. Ver Tabla.

*La capacidad de extracción de aire está dada en m³/hr.

*A continuación hemos elaborado tablas de capacidades de extracción en base a las fórmulas anteriores, facilitando los cálculos.

Fórmula para el cálculo de extracción para cada MegaTon

En base a la tabla inferior ubicar la región donde se van a instalar los para obtener la velocidad de viento y temperatura media anual. Ejemplo: **Chiapas = Velocidad del viento (18) Temp. (22).**

Estado	Viento Km/Hr	Temperatura °C	Estado	Viento Km/Hr	Temperatura °C	Estado	Viento Km/Hr	Temperatura °C
Aguascalientes	10	19	Guerrero	11	27	Quintana Roo	13	28
Baja California norte	14	17	Hidalgo	16	15	San Luís Potosí	15	18
Baja California Sur	12	25	Jalisco	8	20	Sinaloa	11	27
Campeche	12	28	México	14	20	Sonora	13	24
Chiapas	18	22	Michoacán	10	24	Tabasco	11	29
Chihuahua	9	20	Morelos	7	20	Tamaulipas	10	26
Coahuila	11	19	Nayarit	10	12	Tlaxcala	11	15
Colima	10	27	Nuevo León	8	22	Veracruz	15	26
Distrito Federal	15	18	Oaxaca	10	21	Yucatán	12	26
Durango	12	13	Puebla	15	17	Zacatecas	11	26
Guanajuato	14	20	Querétaro	7	18	Quintana Roo		

Posteriormente elegir en las tablas de la siguiente hoja, la cantidad de calor que se siente o produce dentro de la nave, evaluando con las siguientes opciones:

Ejemplo: Nave Industrial donde tenemos hornos (Este caso sería un lugar donde se está acumulando mucho calor, entonces la tabla correspondiente sería: "**Área o lugar con Mucho Calor**", y en base a la ubicación regional de Chiapas, la capacidad de extracción de cada MegaTon modelo **MXMAO-001** al **MXMAO-006** instalado en esa zona es de **26709 m³/Hr**).

* Capacidad de Extracción del MegaTon							
Área o Lugar con Poco Calor							
Diferencial Térmico (Temp. Interior - Exterior) °C =							15
Temperatura de la región (°C)							
							16 20 22 26 30 35
Vel.	7	20608	20653	20675	20720	20765	20821
Viento	9	24753	24797	24820	24865	24910	24966
(K mH r)	11	28897	28942	28964	29009	29054	29110
	13	33042	33087	33109	33154	33199	33255
	15	37186	37231	37254	37299	37343	37400
	17	41331	41376	41398	41443	41488	41544
	18	43403	43448	43471	43515	43560	43616
Área o Lugar con Calor							
Diferencial Térmico (Temp. Interior - Exterior) °C =							23
Temperatura de la región (°C)							
							16 20 22 26 30 35
Vel.	7	22468	22513	22535	22580	22625	22681
Viento	9	26612	26657	26680	26725	26770	26826
(K mH r)	11	30757	30802	30824	30869	30914	30970
	13	34902	34946	34969	35014	35059	35115
	15	39046	39091	39114	39158	39203	39259
	17	43191	43236	43258	43303	43348	43404
	18	45263	45308	45330	45375	45420	45476
Área o Lugar con Mucho Calor							
Diferencial Térmico (Temp. Interior - Exterior) °C =							30
Temperatura de la región (°C)							
							16 20 22 26 30 35
Vel.	7	24095	24140	24163	24207	24252	24308
Viento	9	28240	28285	28307	28352	28397	28453
(K mH r)	11	32384	32429	32452	32497	32541	32598
	13	36529	36574	36596	36641	36686	36742
	15	40674	40718	40741	40786	40831	40887
	17	44818	44863	44885	44930	44975	45031
	18	46890	46935	46958	47003	47048	47104

*La capacidad de extracción de aire está dada en **m3/hr**.
 Las capacidades de extracción de aire están medidas a una altura de 8 metros sobre piso

Galería de Imágenes de los Extractores Atmosféricos Gravitatorios + Eólicos, EcoTon

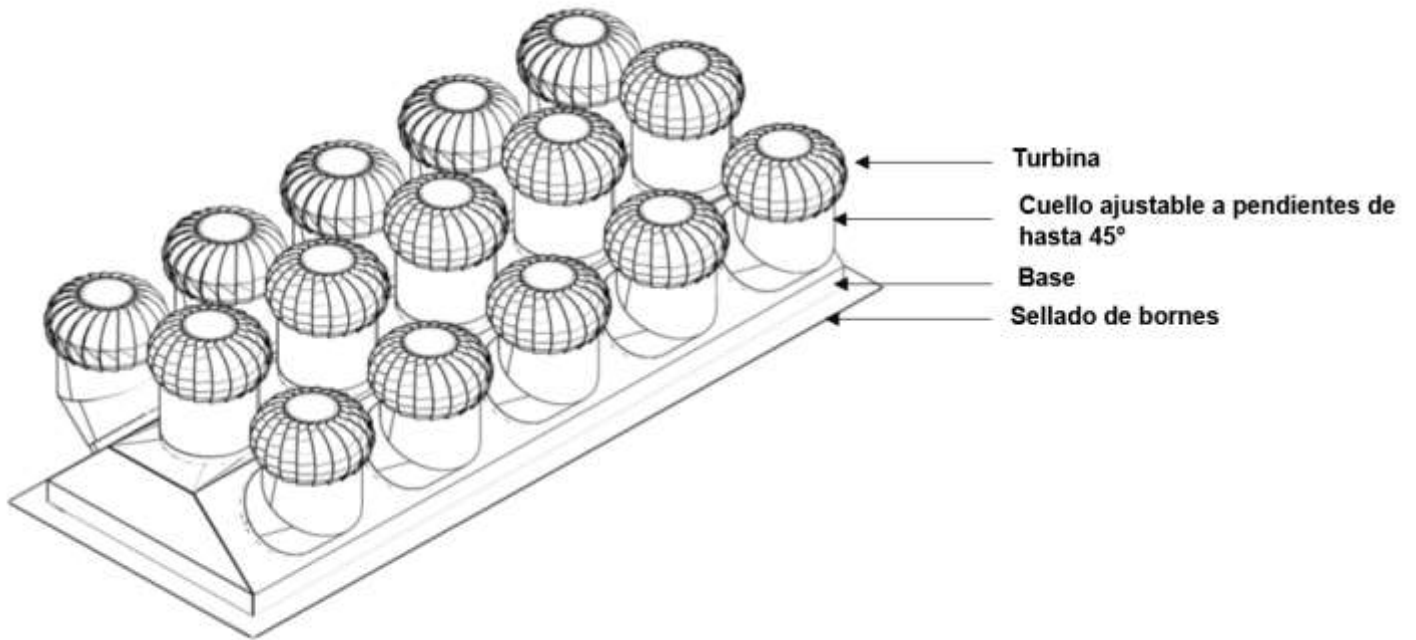

VentDepot Inc. APPENDIX for NOTICE OF ACCEPTANCE (NOA) Supported by MIAMI-DADE COUNTY FLORIDA™ to LOMANCO, INC.™ accepted by the BOARD OF RULES AND APPEALS (BORA)™



MIAMI-DADE COUNTY
 BUILDING CODE COMPLIANCE OFFICE (BCCO)
 PRODUCT CONTROL DIVISION



NOA No.: 15-0831.08
 Expiration Date: 12/22/20
 Approval Date: 11/05/15

VentDepot, Inc.
 233 S Cerritos Ave.
 Azusa, CA 91702

This Appendix provides information about VentDepot, Inc. products, regarding the NOA issued for Lomanco, Inc. applicable rules and regulations governing the use of construction materials to VentDepot, Inc. official and only company that represents and distributes Lomanco, Inc.™ and its products in Mexico, Central America, South America and the Caribbean.

The Miami-Dade County Product Control Division (In Miami Dade County) and/or the AHJ (in areas other than Miami Dade County) reserve the right to have this product or material tested for quality assurance purposes.

This product distributed by VentDepot, Inc. in representation for Lomanco, Inc. is approved as described herein, and has been designed to comply with the Florida Building Code, including the High Velocity Hurricane Zone of the Florida Building Code.

• **DESCRIPTION:**

- BIB-14/BEB14 WhirlyBird® Wind Turbine.
- VentDepot TurboVent USETE-001
- VentDepot Turbo Extractor MXETE-001
- VentDepot TurboJoule MXTUJ-001, MXTUJ-002, MXTUJ-003
- VentDepot EcoTon MXTNT-001, MXTNT-002, MXTNT-003, MXTNT-004, MXTNT-005, MXTNT-006, MXTNT-007, MXTNT-008, MXTNT-009, MXTNT-010, MXTNT-011, MXTNT-012

Above VentDepot products are the equivalent on Lomanco BIB-14/BEB14 WhirlyBird® Wind Turbine.

Each product shall bear a permanent label with the manufacturer's name, Lomanco logo, state and the



following statement:

VentDepot Inc. APPENDIX for NOTICE OF ACCEPTANCE (NOA) Supported by MIAMI-DADE COUNTY FLORIDA™ to LOMANCO, INC.™ accepted by the BOARD OF RULES AND APPEALS (BORA)™



ROOFING COMPONENT APPROVAL

<u>Category:</u>	Roofing
<u>Sub-Category:</u>	Ventilation
<u>Type:</u>	Turbine
<u>Materials:</u>	Aluminum
<u>Deck:</u>	Wood

TRADE NAMES OF PRODUCTS MANUFACTURED OR LABELED BY APPLICANT

<u>Product</u>	<u>Dimensions</u>	<u>Test Specification</u>	<u>Product Description</u>
BIB-14/BEB14 WhirlyBird®	22" wide at base 17-1/8" high Base 0.0253" thick Elbow & Dome 0.032" thick Vanes 0.19" thick Rotr Band 0.0305"thick Extrusions 0.125" thick	TAS 100(A)	14" diameter opening turbine ventilation system



VentDepot Inc, APPENDIX for NOTICE OF ACCEPTANCE (NOA) Supported by MIAMI-DADE COUNTY FLORIDA™ to LOMANCO, INC.™ accepted by the BOARD OF RULES AND APPEALS (BORA)™



MIAMI-DADE COUNTY
BUILDING CODE COMPLIANCE OFFICE (BCCO)
PRODUCT CONTROL DIVISION



**TRADE NAMES OF PRODUCTS MANUFACTURED OR LABELED BY VentDepot, Inc.
representative of Lomanco, Inc.**

<u>Product</u>	<u>Dimensions</u>	<u>Test Specification</u>	<u>Product Description</u>
USETE-001	22" wide at base 23" high 23" depth, 14"Ø Neck, 2bearings Aluminum	TAS 100(A)	17" diameter opening turbine ventilation system
MXETE-001	22" wide at base 23" high 23" depth, 14"Ø Neck, 2bearings Aluminum	TAS 100(A)	17" diameter opening turbine ventilation system
MXTUJ-001	28" x 22" base 37" high 53" wide 47 depth Aluminum	TAS 100(A)	17" diameter opening turbine ventilation system
MXTUJ-002	36" x 22" base 41" high 61" wide 47 depth Aluminum	TAS 100(A)	17" diameter opening turbine ventilation system
MXTUJ-003	48" x 22" base 41" high 73" wide 47 depth Aluminum	TAS 100(A)	17" diameter opening turbine ventilation system
MXTNT-001	32" x 86" base 17" high 13" wide 34" depth 3 Neck 14"Ø, 2 slopes Galvanized	TAS 100(A)	17" diameter opening turbine ventilation system
MXTNT-002	32" x 86" base 17" high 13" wide 34" depth 3 Neck 14"Ø, 1 slope Galvanized	TAS 100(A)	17" diameter opening turbine ventilation system
MXTNT-003	32" x 86" base 17" high 13" wide 34" depth 3 Neck 14"Ø, 2 slopes Powder Coated paint	TAS 100(A)	17" diameter opening turbine ventilation system
MXTNT-004	32" x 86" base 17" high 13" wide	TAS 100(A)	17" diameter opening turbine

VentDepot Inc. APPENDIX for NOTICE OF ACCEPTANCE (NOA) Supported by MIAMI-DADE COUNTY FLORIDA™ to LOMANCO, INC.™ accepted by the BOARD OF RULES AND APPEALS (BORA)™



TRADE NAMES OF PRODUCTS MANUFACTURED OR LABELED BY VentDepot, Inc. representative of Lomanco, Inc.

<u>Product</u>	<u>Dimensions</u>	<u>Test Specification</u>	<u>Product Description</u>
MXTNT-005	32" x 86" base 17" high 13" wide 34" depth 3 Neck 14"O, 2 slopes Aluminum	TAS 100(A)	17" diameter opening turbine ventilation system
MXTNT-006	32" x 86" base 17" high 13" wide 34" depth 3 Neck 14"O, 1 slopes Aluminum	TAS 100(A)	17" diameter opening turbine ventilation system
MXTNT-007	32" x 130" base 17" high 13" wide 34" depth 5 Neck 14"O, 2 slopes Galvanized	TAS 100(A)	17" diameter opening turbine ventilation system
MXTNT-008	32" x 130" base 17" high 13" wide 34" depth 5 Neck 14"O, 1 slopes Galvanized	TAS 100(A)	17" diameter opening turbine ventilation system
MXTNT-009	32" x 130" base 17" high 13" wide 34" depth 5 Neck 14"O, 2 slopes Powder Coated paint	TAS 100(A)	17" diameter opening turbine ventilation system
MXTNT-010	32" x 130" base 17" high 13" wide 34" depth 5 Neck 14"O, 1 slopes Powder Coated paint	TAS 100(A)	17" diameter opening turbine ventilation system
MXTNT-011	32" x 130" base 17" high 13" wide 34" depth 5 Neck 14"O, 2 slopes Aluminum	TAS 100(A)	17" diameter opening turbine ventilation system
MXTNT-012	32" x 130" base 17" high 13" wide 34" depth 5 Neck 14"O, 1 slopes Aluminum	TAS 100(A)	17" diameter opening turbine ventilation system

VentDepot Inc. APPENDIX for NOTICE OF ACCEPTANCE (NOA) Supported by MIAMI-DADE COUNTY FLORIDA™ to LOMANCO, INC.™ accepted by the BOARD OF RULES AND APPEALS (BORA)™



BUILDING CODE COMPLIANCE OFFICE (BCCO)
 PRODUCT CONTROL DIVISION



LIMITATIONS:

1. Refer to applicable building codes for required ventilation.
2. This acceptance is for installations over asphaltic shingle or low slope roofing.
3. The BIB-14/BEB14 WhirlyBird[®] Wind Turbine, **VentDepot TurboVent** USETE-001, **VentDepot Turbo Extractor** MXETE-001, **VentDepot TurboJoule** MXTUJ-001, MXTUJ-002, MXTUJ-003, **VentDepot EcoTon** MXTNT-001, MXTNT-002, MXTNT-003, MXTNT-004, MXTNT-005, MXTNT-006, MXTNT-007, MXTNT-008, MXTNT-009, MXTNT-010, MXTNT-011, MXTNT-012 turbine roof ventilators shall not be installed on roof mean heights greater than 33ft.

DETAILED DRAWINGS:

The detailed drawings of BIB-14/BEB14 WhirlyBird[®] Wind Turbine, **VentDepot TurboVent** USETE-001, **VentDepot Turbo Extractor** MXETE-001, **VentDepot TurboJoule** MXTUJ-001, MXTUJ-002, MXTUJ-003, **VentDepot EcoTon** MXTNT-001, MXTNT-002, MXTNT-003, MXTNT-004, MXTNT-005, MXTNT-006, MXTNT-007, MXTNT-008, MXTNT-009, MXTNT-010, MXTNT-011, MXTNT-012 turbine roof ventilators are shown in page 4 to 5 of **NOA No.: 10-0928.05 Expiration Date:**

VentDepot . Com

Aire Acondicionado, Ventilación y Calefacción Ecológica
Call Center Nacional: 01 800 999.1516
Call Center México: (55) 5822.1516
Tienda: www.VentDepot.com E-mail: ventas@ventdepot.com



MegaTon



**BUILDING CODE COMPLIANCE OFFICE (BCCO)
PRODUCT CONTROL DIVISION**

MIAMI-DADE COUNTY, FLORIDA
METRO-DADE FLAGLER BUILDING
140 WEST FLAGLER STREET, SUITE 1603
MIAMI, FLORIDA 33130-1563
(305) 375-2901 FAX (305) 375-2908

NOTICE OF ACCEPTANCE (NOA)

Lomanco, Inc.
2101 W. Main Street
Jacksonville, AR 72076

SCOPE:

This NOA is being issued under the applicable rules and regulations governing the use of construction materials. The documentation submitted has been reviewed by Miami-Dade County Product Control Division and accepted by the Board of Rules and Appeals (BORA) to be used in Miami Dade County and other areas where allowed by the Authority Having Jurisdiction (AHJ).

This NOA shall not be valid after the expiration date stated below. The Miami-Dade County Product Control Division (In Miami Dade County) and/or the AHJ (in areas other than Miami Dade County) reserve the right to have this product or material tested for quality assurance purposes. If this product or material fails to perform in the accepted manner, the manufacturer will incur the expense of such testing and the AHJ may immediately revoke, modify, or suspend the use of such product or material within their jurisdiction. BORA reserves the right to revoke this acceptance, if it is determined by Miami-Dade County Product Control Division that this product or material fails to meet the requirements of the applicable building code.

This product is approved as described herein, and has been designed to comply with the Florida Building Code, including the High Velocity Hurricane Zone of the Florida Building Code.

DESCRIPTION: BIB-14/ BEB-14 WhirlyBird® Wind Turbine

LABELING: Each unit shall bear a permanent label with the manufacturer's name or logo, city, state and following statement: "Miami-Dade County Product Control Approved", unless otherwise noted herein.

RENEWAL of this NOA shall be considered after a renewal application has been filed and there has been no change in the applicable building code negatively affecting the performance of this product.

TERMINATION of this NOA will occur after the expiration date or if there has been a revision or change in the materials, use, and/or manufacture of the product or process. Misuse of this NOA as an endorsement of any product, for sales, advertising or any other purposes shall automatically terminate this NOA. Failure to comply with any section of this NOA shall be cause for termination and removal of NOA.

ADVERTISEMENT: The NOA number preceded by the words Miami-Dade County, Florida, and followed by the expiration date may be displayed in advertising literature. If any portion of the NOA is displayed, then it shall be done in its entirety.

INSPECTION: A copy of this entire NOA shall be provided to the user by the manufacturer or its distributors and shall be available for inspection at the job site at the request of the Building Official.

This renews NOA # 05-0823.06 consists of pages 1 through 5.
The submitted documentation was reviewed by Alex Tigera.

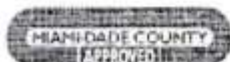

ROOFING COMPONENT APPROVAL

Category: Roofing
Sub-Category: Ventilation
Type: Turbine
Materials: Aluminum
Deck: Wood

TRADE NAMES OF PRODUCTS MANUFACTURED OR LABELED BY APPLICANT:

<u>Product</u>	<u>Dimensions</u>	<u>Test Specification</u>	<u>Product Description</u>
BIB-14/ BEB-14 WhirlyBird®	22" wide at base 17-1/8" high Base 0.0253" thick Elbow & Dome 0.032" thick Vanes 0.019" thick Rotor Band 0.0305" thick Extrusions 0.125" thick	TAS 100(A)	14" diameter opening turbine ventilation system.

MANUFACTURING LOCATION

1 Jacksonville, AR

EVIDENCE SUBMITTED

<u>Test Agency</u>	<u>Test Identifier</u>	<u>Description</u>	<u>Date</u>
PRI Asphalt Technologies, Inc.	LOM-019-02-01	TAS 100(A)	09/01/10





APPROVED ASSEMBLY:

- System Type A:** Mechanical attachment of turbine vent over composite shingles
- Cutout:** At chosen location (see Lomanco instructions for proper placement) and centered between two roof rafters, cut a 14" diameter hole through shingles and sheathing boards. Seal around top and sides of hole with approved roofing cement.
- Installation**
- Determine roof pitch in compliance with Lomanco instructions and align roof pitch number on elbow with indicator line on flashing. Place three short screws through holes that line up with pre-drilled holes in base.
- Place mounting base unit flat on the shingles on its flashing, and coat underside of base flashing with roofing cement. In its pitch-adjusted position, carefully slide upper half of flashing up roof beneath shingles previously rolled back until base is centered over cutout. Rolling back the shingles where necessary, and rechecking pitch setting for vertical alignment, secure the base unit to the roof deck with a minimum of fourteen ring shank roofing nails, equally spaced, approximately $\frac{3}{8}$ " from edge of base per detail drawing "Base". Nails shall be of sufficient length to penetrate through roof sheathing a minimum of $\frac{1}{2}$ ". Apply roofing cement to underside of shingles overlapping flashing, and press them down onto the flashing.
- Rotate top of elbow to level position by turning counterclockwise. Place locking clamp across seam and tighten as shown in Lomanco instructions with approved sheet metal screw. Seal all seams and nails with approved roofing cement.
- Position whirlybird on the base. Line up the pre-drilled holes in the brackets and base and fasten with approved long sheet metal screws.
- After installation, verify that whirlybird turns freely. If necessary, minor adjustment may be made by gently prying lowest point of turbine upward to remove any wobble.
- Net Free Area:** Refer to manufacturers published literature.
- Slope:** Minimum 2" on 12"

LIMITATIONS:

1. Refer to applicable building codes for required ventilation.
2. This acceptance is for installations over asphaltic shingle or low slope roofing.
3. BIB-14/BEB-14 Whirlybird® turbine roof ventilators shall not be installed on roof mean heights greater than 33 ft



DETAIL DRAWINGS

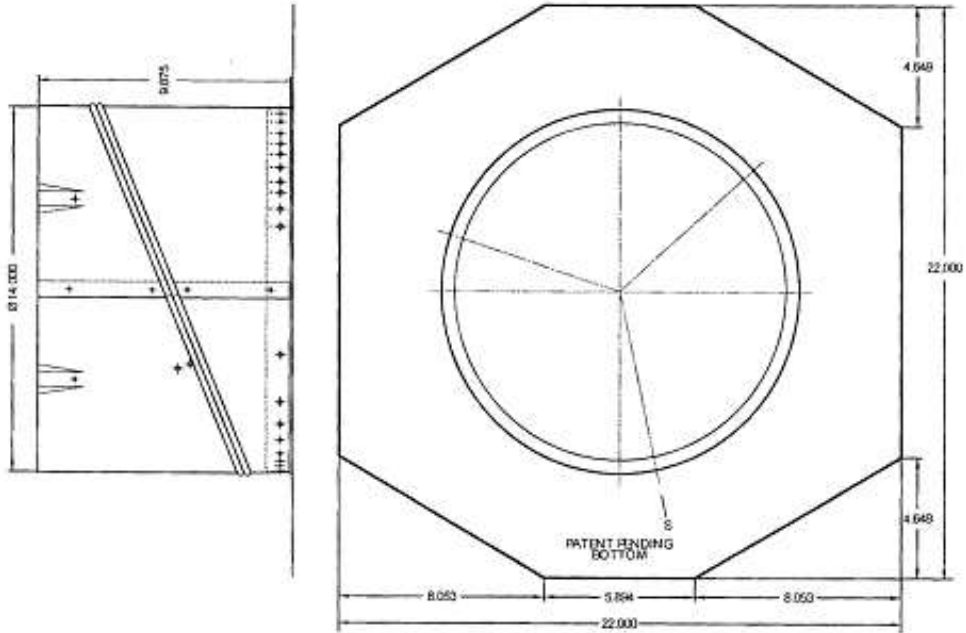

Base

DETAILED DRAWINGS (CONTINUED)

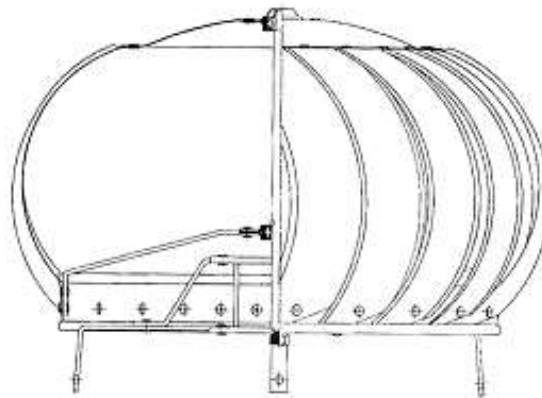
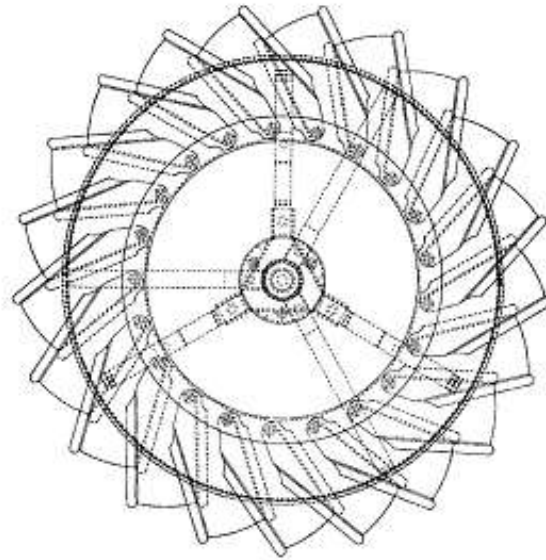

BIB-14, BEB-14
END OF THIS ACCEPTANCE

